

MR350S

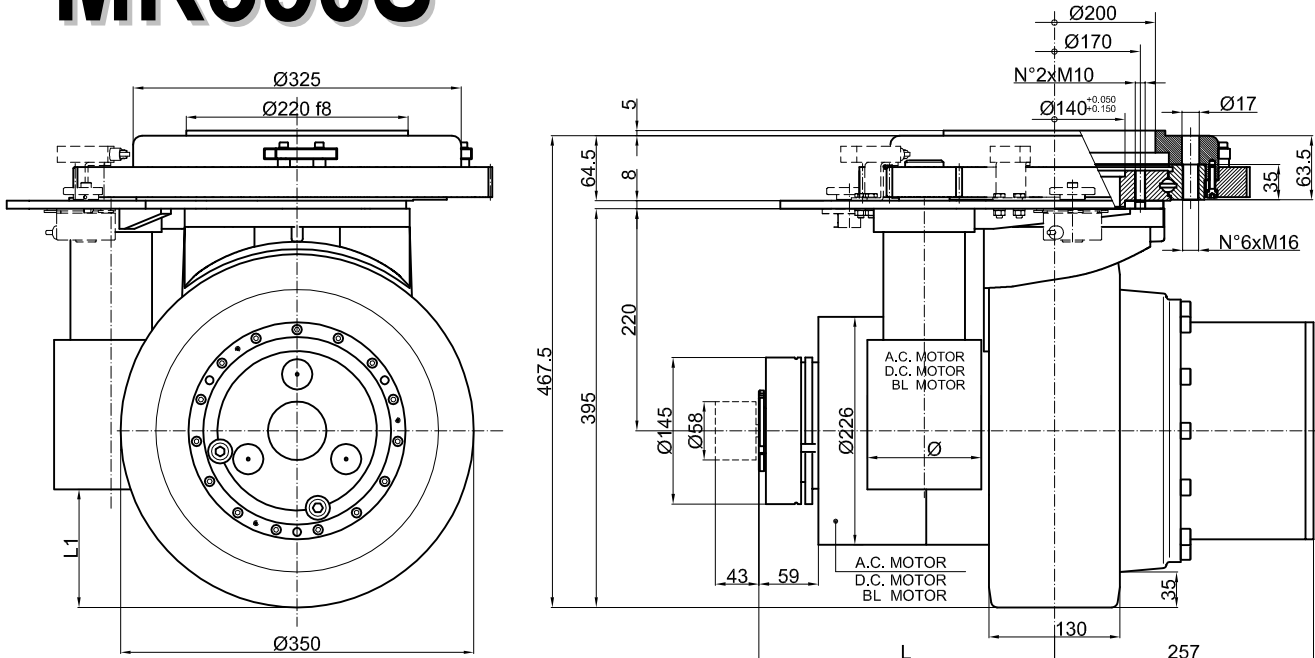

MR350FMS

	A.C. MOTOR	D.C. MOTOR	BL MOTOR
L	293	243	269
R1	260	216	226
R2	295	247	273
R3	337	287	314
Ø	126	113	119
L1	83	117	105

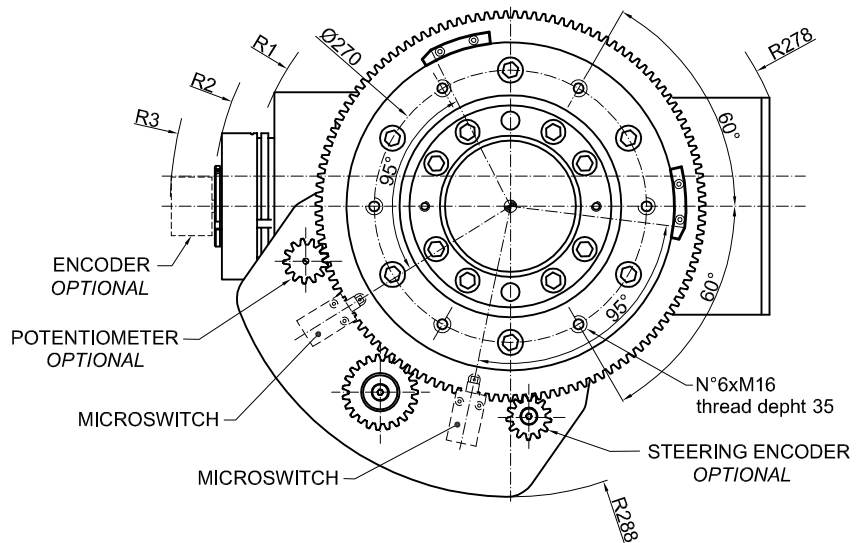

TECHNICAL DATAS – DATI TECNICI

		A.C. MOTOR	D.C. MOTOR	BL MOTOR
POWER - POTENZA	W	3000 ÷ 5000		
VOLTAGE - TENSIONE	V	24 ÷ 96		
GEAR RATIO – RAPPORTO DI RIDUZIONE	i	22:1 - 30:1		
STEERING SYSTEM RATIO – RAPPORTO DI RIDUZIONE SISTEMA STERZO	i	282		
WHEEL - RUOTA	mm	Ø350x130		
MAX WHEEL TORQUE – COPPIA MASSIMA ALLA RUOTA	Nm	2000		
MAX WHEEL LOAD – CARICO MASSIMO SULLA RUOTA	kg	-		
		rubber – gomma		
		polyurethan – poliuretano		
		vulkollan – vukollan		
BRAKE TORQUE – COPPIA FRENO	Nm	40		
WEIGHT - PESO	kg	170		