



65000

IT EN DE FR ES PT

	i	Mc [kNm]				n _{1max} [min ⁻¹]	Pt [kW]	Kg				
		n ₂ x h	n ₂ x h	n ₂ x h	n ₂ x h			M	P	CPC	F	FS
		10.000	20.000	50.000	100.000							
PG 65001	3.84	730.3	657.5	572.3	540.0	100	160	3175	—	—	2850	2907
PG 65002	14.13	730.3	657.5	572.3	540.0	200	110	4015	—	—	3690	3747
	19.00	730.3	657.5	572.3	540.0							
PG 65003	55.88	730.3	657.5	572.3	540.0	1200	93	4209	—	—	3884	3941
	75.00	730.3	657.5	572.3	540.0							
	96.06	730.3	657.5	572.3	540.0							
PG 65004	198.69	730.3	657.5	572.3	540.0	2000	70	4268	—	—	3943	4000
	266.79	730.3	657.5	572.3	540.0							
	306.60	730.3	657.5	572.3	540.0							
	362.67	730.3	657.5	572.3	540.0							
	411.67	730.3	657.5	572.3	540.0							
	482.89	730.3	657.5	572.3	540.0							
	537.92	730.3	657.5	572.3	540.0							
	648.38	730.3	657.5	572.3	540.0							
768.46	730.3	657.5	572.3	540.0								
PG 65005	1026.58	730.3	657.5	572.3	540.0	2800	49	4284	—	—	3959	4016
	1214.84	730.3	657.5	572.3	540.0							
	1326.50	730.3	657.5	572.3	540.0							
	1496.00	730.3	657.5	572.3	540.0							
	1616.87	730.3	657.5	572.3	540.0							
	1736.35	730.3	657.5	572.3	540.0							
	1873.78	730.3	657.5	572.3	540.0							
	1958.22	730.3	657.5	572.3	540.0							
	2127.00	730.3	657.5	572.3	540.0							
	2218.92	730.3	657.5	572.3	540.0							
	2403.72	730.3	657.5	572.3	540.0							
	2779.25	730.3	657.5	572.3	540.0							
	3046.40	730.3	657.5	572.3	540.0							
	3500.95	730.3	657.5	572.3	540.0							
	3899.91	730.3	657.5	572.3	540.0							
	4610.73	730.3	657.5	572.3	540.0							
	5571.30	730.3	657.5	572.3	540.0							



	i	Mc [kNm]				n1max [min ⁻¹]	Pt [kW]	Kg				
		n ₂ x h	n ₂ x h	n ₂ x h	n ₂ x h			M	P	CPC	F	FS
		10.000	20.000	50.000	100.000							
PGA 65005	610.27	730.3	657.5	572.3	540.0	2500	50	4390	—	—	4065	4122
	735.60	730.3	657.5	572.3	540.0							
	819.42	730.3	657.5	572.3	540.0							
	927.24	730.3	657.5	572.3	540.0							
	987.70	730.3	657.5	572.3	540.0							
	1113.90	730.3	657.5	572.3	540.0							
	1246.00	730.3	657.5	572.3	540.0							
	1426.00	730.3	657.5	572.3	540.0							
	1500.69	730.3	657.5	572.3	540.0							
	1692.44	730.3	657.5	572.3	540.0							
	1960.90	730.3	657.5	572.3	540.0							
	2166.62	730.3	657.5	572.3	540.0							
	2510.29	730.3	657.5	572.3	540.0							
	3025.79	730.3	657.5	572.3	540.0							
3586.13	730.3	657.5	572.3	540.0								



(n₂ x h = 20.000)
 $M_{max} = M_c \times 1.3$

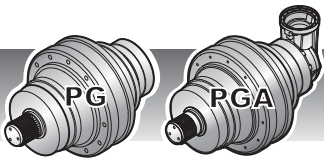

65000

IT EN DE FR ES PT

F

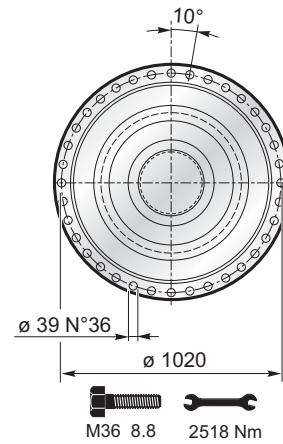
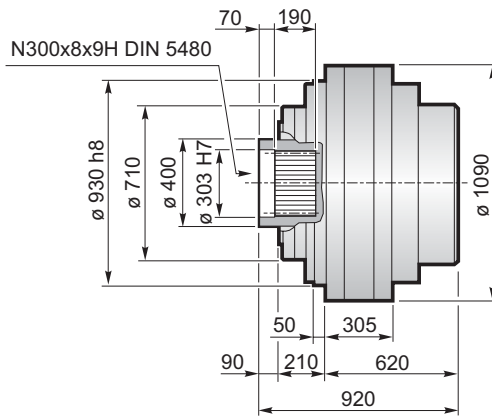

FS

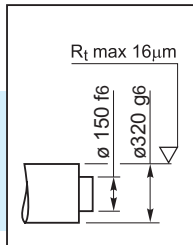
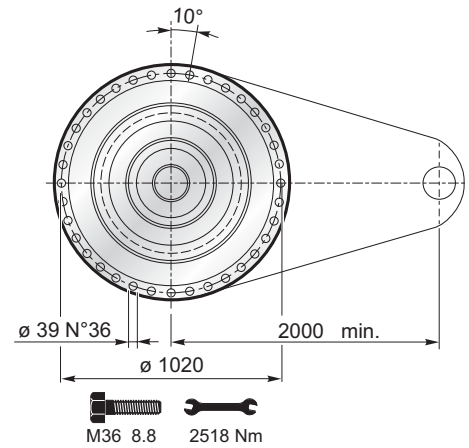
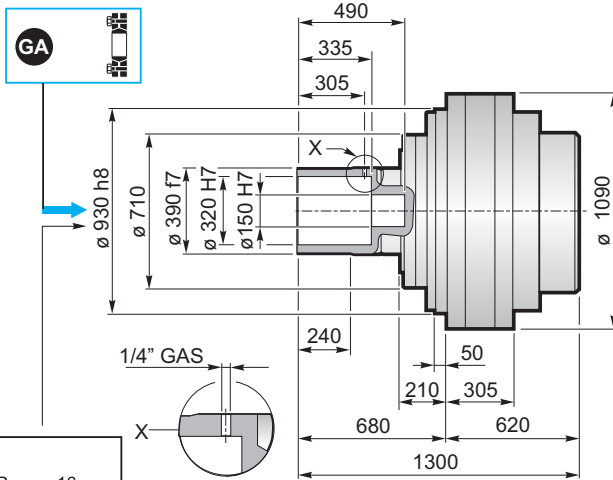

$M_{max} = 814.5 \text{ kNm}$

La coppia massima indicata è valida solo con calettatori forniti da Planetary Drives
 The maximum torque indicated is valid only with shrink discs supplied by Planetary Drives
 Das dargestellte, maximale Drehmoment gilt nur mit von Planetary Drives gelieferter Schrumpfscheibe
 Le couple maximal indiqué n'est valable qu'avec les frettes de serrage fournis par Planetary Drives
 El momento máximo indicado sólo es válido con discos de contracción suministrados por Planetary Drives
 O torque máximo indicado é válido exclusivamente com discos de contração fornecidos pela Planetary Drives

GA

Giunto di attrito / Shrink disc
 Schrumpfscheibe / Frette de serrage
 Disco de contracción / Disco de contração

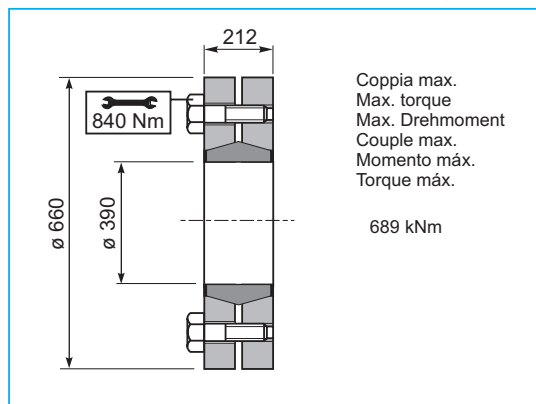

Coppia max.
 Max. torque
 Max. Drehmoment
 Couple max.
 Momento máx.
 Torque máx.

689 kNm

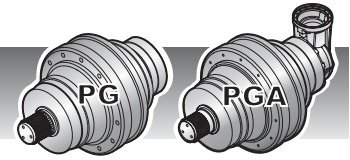

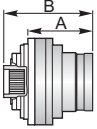
	PG ...F						
	A	B	RA	RB	EF	EDF	
PG 65002	903.5	1203.5					
PG 65003	1124.5	1424.5					
PG 65004	1231.5	1531.5		•			
PG 65005	1303	1603	•	o	•		

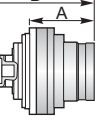
	PG ...FS						
	A	B	RA	RB	EF	EDF	
PG 65002	903.5	1583.5					
PG 65003	1124.5	1804.5					
PG 65004	1231.5	1911.5		•			
PG 65005	1303	1983.5	•	o	•		

⚠	A	B	•
	A+13.5	B+13.5	o

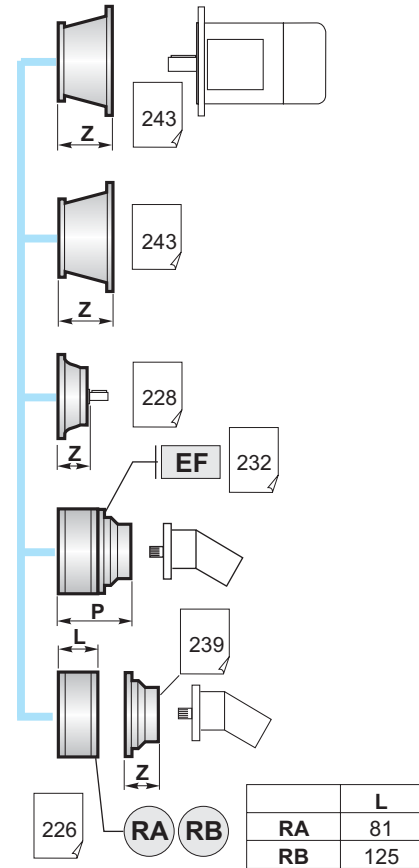

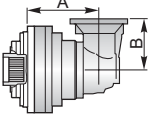
	PGA ...F					
	A	B	RA	RB	EF	
PGA 65005	1366.5	315		•		

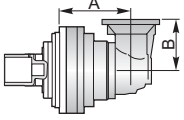
	PGA ...FS					
	A	B	RA	RB	EF	
PGA 65005	1366.5	315		•		

