



5000



	i	Mc [kNm]				n _{1max} [min ⁻¹]	Pt [kW]	Kg				
		n ₂ x h	n ₂ x h	n ₂ x h	n ₂ x h			M	P	CPC	F	FS
		10.000	20.000	50.000	100.000							
PG 5001	4.00	68.69	60.80	51.74	45.80	1200	60	314	—	418	256	269
	5.10	50.28	44.50	37.87	33.52							
	6.00	40.11	35.50	30.21	26.74							
PG 5002	14.0	68.69	60.80	51.74	45.80	2000	38	373	—	477	315	328
	16.9	68.69	60.80	51.74	45.80							
	21.6	50.28	44.50	37.87	33.52							
	26.9	68.69	60.80	51.74	45.80							
	28.3	50.28	44.50	37.87	33.52							
	33.6	40.11	35.50	30.21	26.74							
	40.5	40.11	35.50	30.21	26.74							
	53.1	68.69	60.80	51.74	45.80							
PG 5003	64.0	68.69	60.80	51.74	45.80	2800	25	389	—	493	331	344
	74.2	50.28	44.50	37.87	33.52							
	84.3	68.69	60.80	51.74	45.80							
	92.9	50.28	44.50	37.87	33.52							
	107.9	50.28	44.50	37.87	33.52							
	116.9	50.28	44.50	37.87	33.52							
	130.1	50.28	44.50	37.87	33.52							
	138.6	40.11	35.50	30.21	26.74							
	157.2	50.28	44.50	37.87	33.52							
	170.1	50.28	44.50	37.87	33.52							
	205.5	50.28	44.50	37.87	33.52							
	247.7	50.28	44.50	37.87	33.52							
	293.6	40.11	35.50	30.21	26.74							
	PG 5004	324.7	68.69	60.80	51.74							
358.5		68.69	60.80	51.74	45.80							
391.4		68.69	60.80	51.74	45.80							
432.1		68.69	60.80	51.74	45.80							
471.8		68.69	60.80	51.74	45.80							
511.5		68.69	60.80	51.74	45.80							
564.6		68.69	60.80	51.74	45.80							
591.0		68.69	60.80	51.74	45.80							
616.6		68.69	60.80	51.74	45.80							
686.3		68.69	60.80	51.74	45.80							
789.3		50.28	44.50	37.87	33.52							
878.7		50.28	44.50	37.87	33.52							
952.5		50.28	44.50	37.87	33.52							
1061.7		50.28	44.50	37.87	33.52							
1151.0		50.28	44.50	37.87	33.52							
1258.3		40.11	35.50	30.21	26.74							
1387.3		50.28	44.50	37.87	33.52							
1672.2		50.28	44.50	37.87	33.52							
1981.9	40.11	35.50	30.21	26.74								



	i	Mc [kNm]				n1max [min ⁻¹]	Pt [kW]	Kg				
		n ₂ x h	n ₂ x h	n ₂ x h	n ₂ x h			M	P	CPC	F	FS
		10.000	20.000	50.000	100.000							
PGA 5002	12.1	68.69	60.80	51.74	45.80	2000	38	364	—	468	306	319
	15.5	50.28	44.50	37.87	33.52							
	18.4	40.11	35.50	30.21	26.74							
	23.6	50.28	44.50	37.87	33.52							
	27.9	40.11	35.50	30.21	26.74							
PGA 5003	58.5	68.69	60.80	51.74	45.80	2800	25	410	—	514	293	306
	76.5	68.69	60.80	51.74	45.80							
	97.9	50.28	44.50	37.87	33.52							
	118.1	50.28	44.50	37.87	33.52							
	139.9	40.11	35.50	30.21	26.74							
	154.3	50.28	44.50	37.87	33.52							
	220.4	40.11	35.50	30.21	26.74							
PGA 5004	241.5	68.69	60.80	51.74	45.80	2800	20	429	—	533	371	384
	288.9	68.69	60.80	51.74	45.80							
	315.7	68.69	60.80	51.74	45.80							
	351.2	68.69	60.80	51.74	45.80							
	395.2	68.69	60.80	51.74	45.80							
	455.4	68.69	60.80	51.74	45.80							
	506.3	50.28	44.50	37.87	33.52							
	543.3	50.28	44.50	37.87	33.52							
	587.6	50.28	44.50	37.87	33.52							
	668.9	50.28	44.50	37.87	33.52							
	708.7	50.28	44.50	37.87	33.52							
	797.4	50.28	44.50	37.87	33.52							
	856.3	50.28	44.50	37.87	33.52							
	926.0	50.28	44.50	37.87	33.52							
	961.2	50.28	44.50	37.87	33.52							
	1119.0	50.28	44.50	37.87	33.52							
	1348.8	50.28	44.50	37.87	33.52							
1598.6	40.11	35.50	30.21	26.74								



(n₂ x h = 20.000)
 $M_{max} = M_c \times 2$

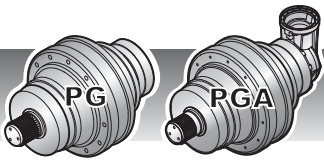

5000

IT EN DE FR ES PT

MS

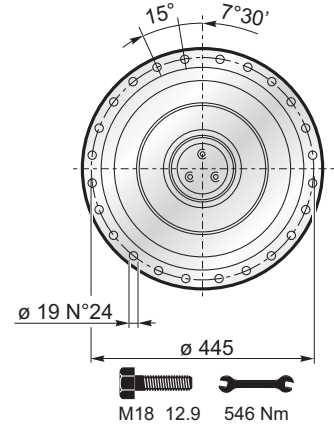
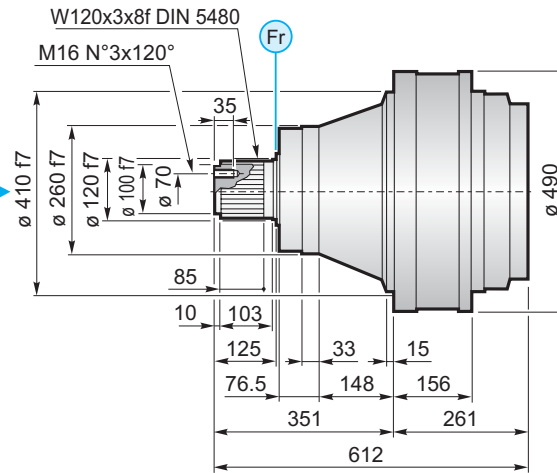
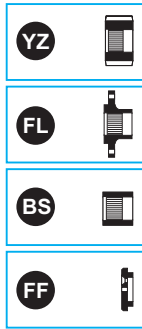

MC

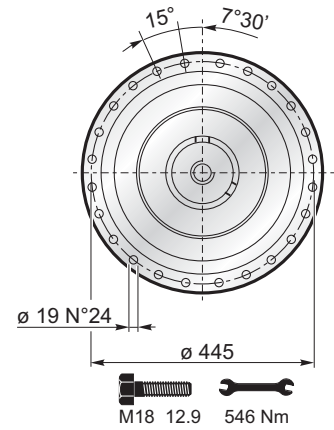
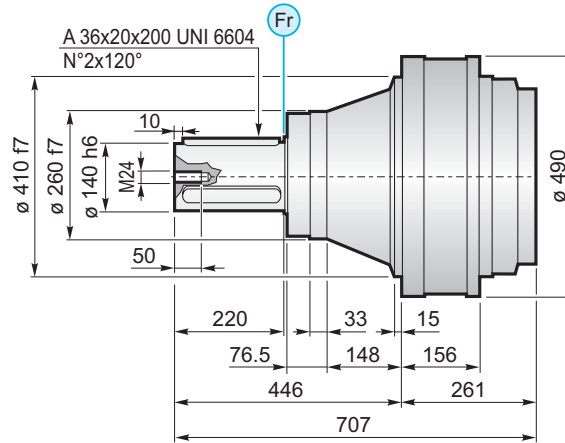

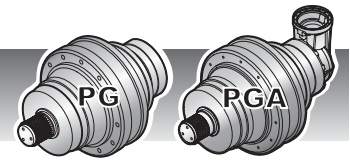

F

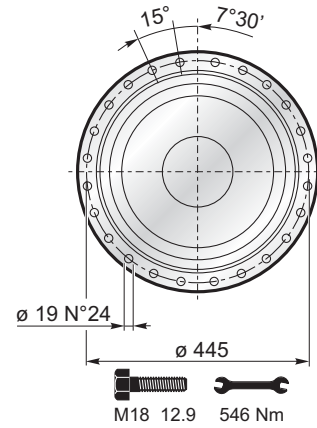
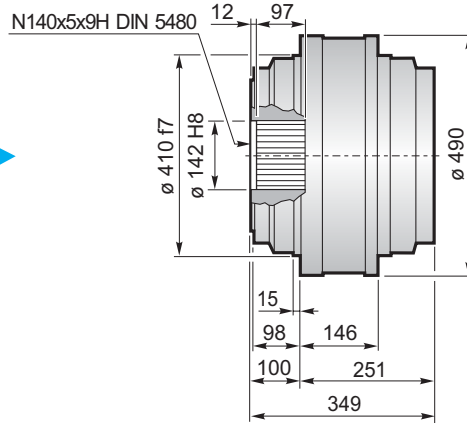
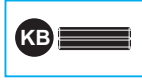

FS

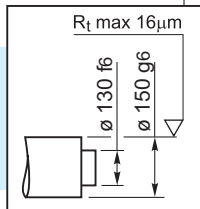
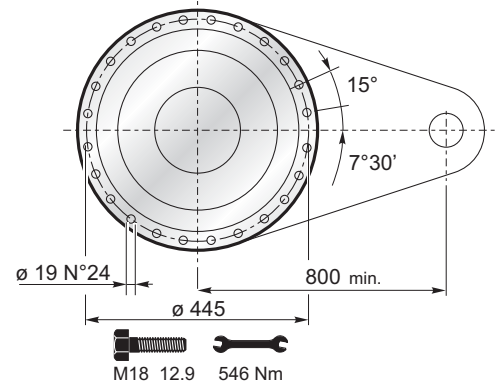
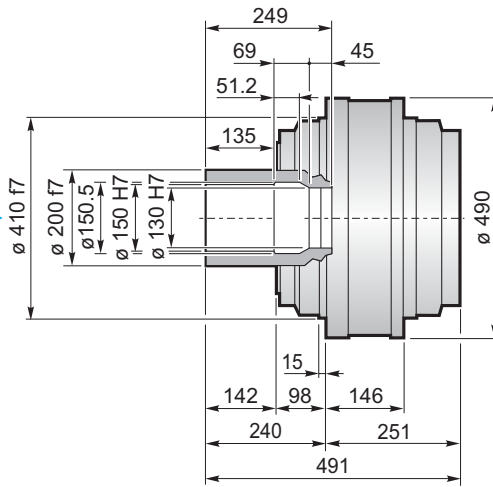

$M_{max} = 92.5 \text{ kNm}$

La coppia massima indicata è valida solo con calettatori forniti da Planetary Drives
 The maximum torque indicated is valid only with shrink discs supplied by Planetary Drives
 Das dargestellte, maximale Drehmoment gilt nur mit von Planetary Drives gelieferter Schrumpfscheibe
 Le couple maximal indiqué n'est valable qu'avec les frettes de serrage fournis par Planetary Drives
 El momento máximo indicado sólo es válido con discos de contracción suministrados por Planetary Drives
 O torque máximo indicado é válido exclusivamente com discos de contração fornecidos pela Planetary Drives

CPC

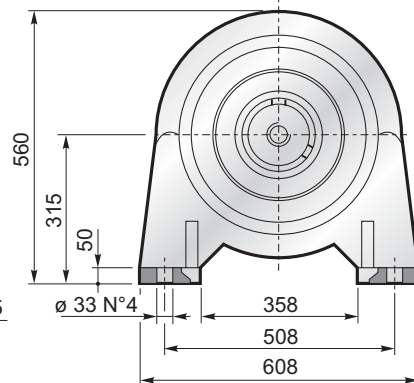
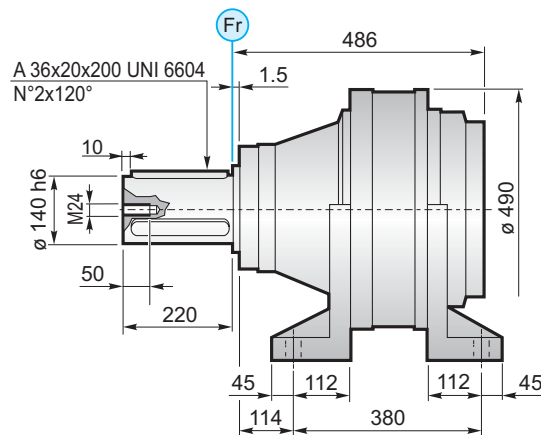

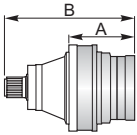

5000

	PG ...MS						
	A	B	RA	RB	EF	EDF	
PG 5001	261	612					
PG 5002	368	719		•			
PG 5003	439.5	790.5	•	o	•		
PG 5004	500.5	851.5	•			•	

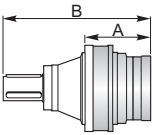
	PG ...MC						
	A	B	RA	RB	EF	EDF	
PG 5001	261	707					
PG 5002	368	814		•			
PG 5003	439.5	885.5	•	o	•		
PG 5004	500.5	946.5	•			•	

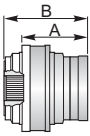
	PG ...F						
	A	B	RA	RB	EF	EDF	
PG 5001	251	349					
PG 5002	358	456		•			
PG 5003	429.5	527.5	•	o	•		
PG 5004	490.5	588.5	•			•	

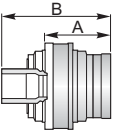
	PG ...FS						
	A	B	RA	RB	EF	EDF	
PG 5001	251	491					
PG 5002	358	598		•			
PG 5003	429.5	669.5	•	o	•		
PG 5004	490.5	730.5	•			•	

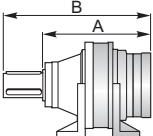
	PG ...CPC						
	A	B	RA	RB	EF	EDF	
PG 5001	486	706					
PG 5002	593	813		•			
PG 5003	664.5	884.5	•	o	•		
PG 5004	725.5	945.5	•			•	

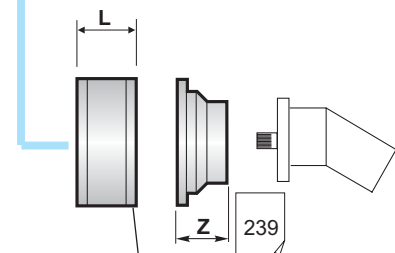
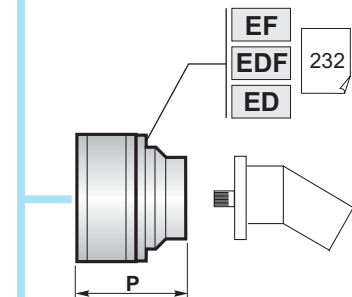
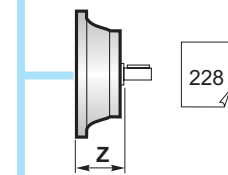
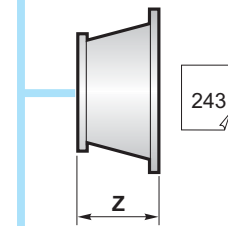
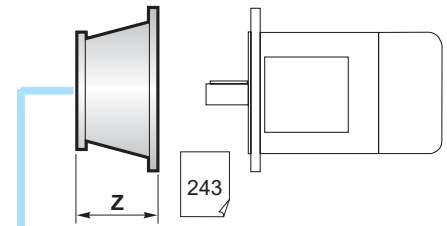

226	RA	RB	L
	RA		81
	RB		125

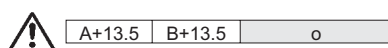



	PGA ...MS				
	A	B	RA	RB	EF
PGA 5002	442	315		•	
PGA 5003	456	240	•	o	•
PGA 5004	541	240	•		•

	PGA ...MC				
	A	B	RA	RB	EF
PGA 5002	442	315		•	
PGA 5003	456	240	•	o	•
PGA 5004	541	240	•		•

	PGA ...F				
	A	B	RA	RB	EF
PGA 5002	432	315		•	
PGA 5003	446	240	•	o	•
PGA 5004	531	240	•		•

	PGA ...FS				
	A	B	RA	RB	EF
PGA 5002	432	315		•	
PGA 5003	446	240	•	o	•
PGA 5004	531	240	•		•

	PGA ...CPC				
	A	B	RA	RB	EF
PGA 5002	667	315		•	
PGA 5003	681	240	•	o	•
PGA 5004	766	240	•		•

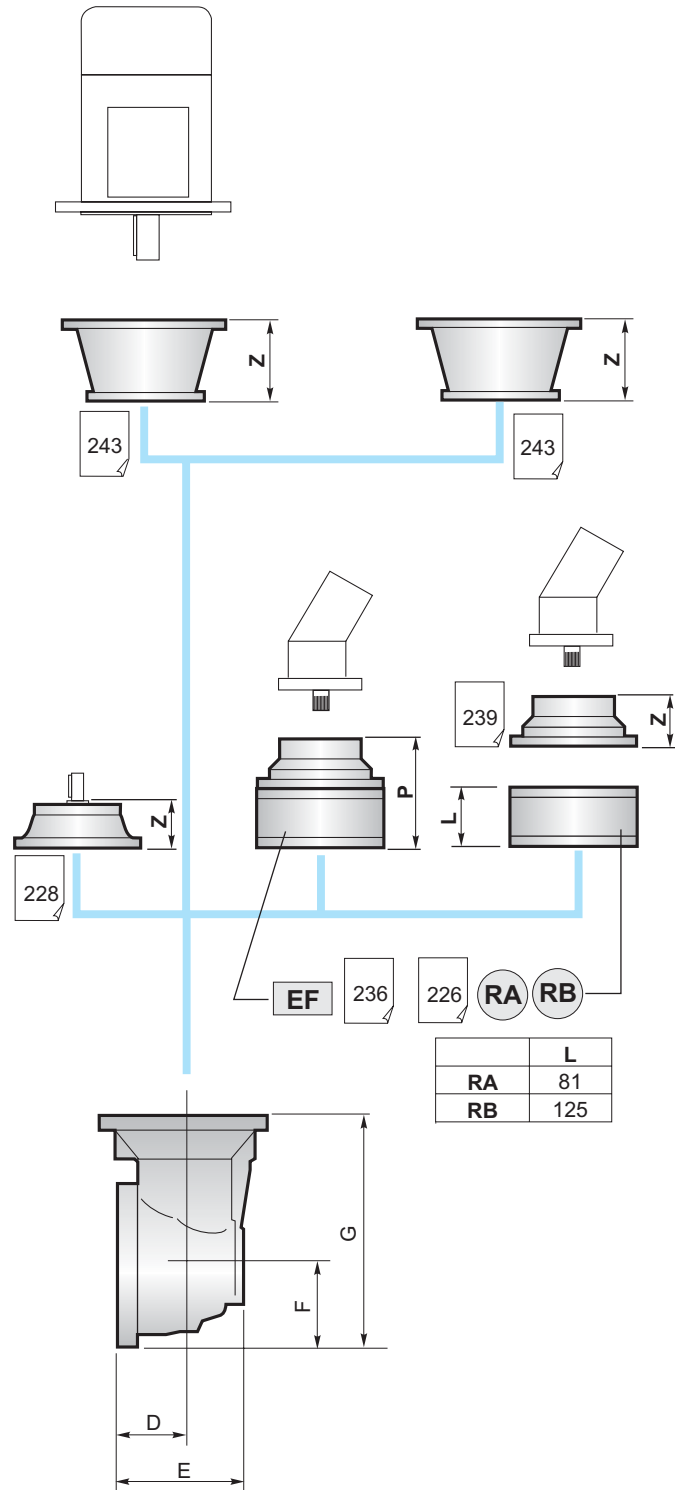

	D	E	F	G
PGA 5002	88	256	235	550
PGA 5003	88	164	140	380
PGA 5004	88	164	140	380

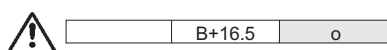

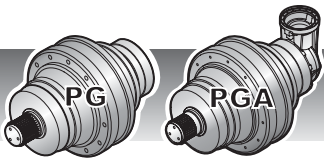

5000

IT EN DE FR ES PT

BS

Boccola scanalata / Splined bushing
Innenverzahnte Buchse / Moyeu cannelé
Casquillo ranurado / Bucha estriada

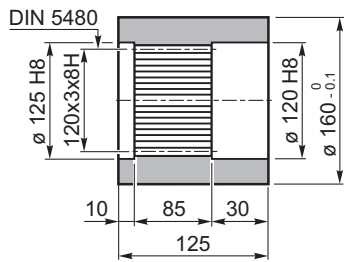

Materiale / Material
Material / Matière
Material / Material

UNI C40
SAE 1040
DIN Ck40

Codice / Code
Bestell - Nr. / Code
Código / Código

1719.104.076

KB

Barra scanalata / Splined rod
Außenverzahnte Welle / Arbre cannelé
Barra ranurada / Barra estriada

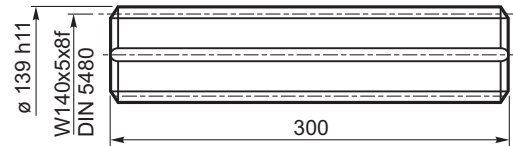

Materiale / Material
Material / Matière
Material / Material

UNI 16CrNi4
bonificato / hardened and tempered
vergütet / bonifié
bonificado / endurecido e temperado

Codice / Code
Bestell - Nr. / Code
Código / Código

1703.564.042

FL

Flangia / Flange
Flansch / Bride
Brida / Flange

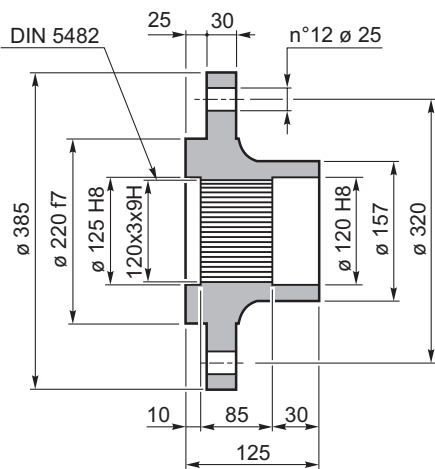

Codice / Code
Bestell - Nr. / Code
Código / Código

1719.103.098

GA

Giunto di attrito / Shrink disc
Schrumpfscheibe / Frette de serrage
Disco de contracción / Disco de contração

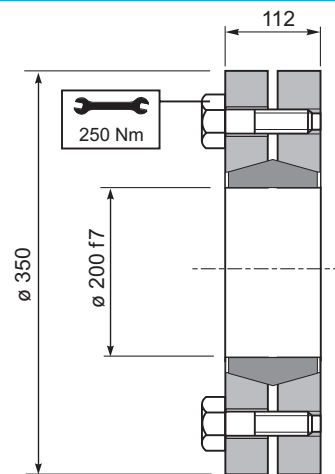

Coppia max.
Max. torque
Max. Drehmoment
Couple max.
Momento máx.
Torque máx.

92,5 kNm

Codice / Code
Bestell - Nr. / Code
Código / Código

9015.200.000

FF

Fondello di arresto / Stop bottom plate
Endscheibe / Bouchon de fermeture
Tapón de detención / Fundo de batente

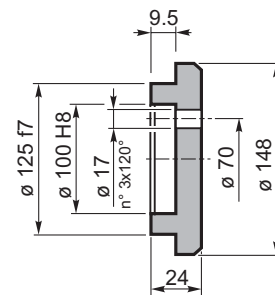

Codice / Code
Bestell - Nr. / Code
Código / Código

5701.005.000

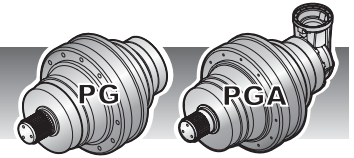

CARICHI RADIALI (Fr)

Nei diagrammi seguenti sono riportati i carichi radiali e i coefficienti K per rapportarli al valore $n_2 \times h$ desiderato.

RADIAL LOADS (Fr)

The following curves show the radial loads and the K factors to obtain the required $n_2 \times h$ value.

RADIALLAST (Fr)

In den nachstehenden Diagrammen ist die Radiallast und der Koeffizient K dargestellt und kann mit dem gewünschten Wert $n_2 \times h$ verglichen werden.

CHARGES RADIALES (Fr)

Dans les diagrammes suivants sont indiqués les charges radiales et les facteurs K de façon à obtenir la valeur $n_2 \times h$ désirée.

CARGAS AXIALES (Fr)

En los siguientes diagramas se indican las cargas radiales y los coeficientes K para obtener el valor requerido $n_2 \times h$.

CARGAS AXIAIS (Fr)

Nos diagramas seguintes são indicadas as cargas radiais e os coeficientes K para obter o valor $n_2 \times h$ desejado.

M - CPC*

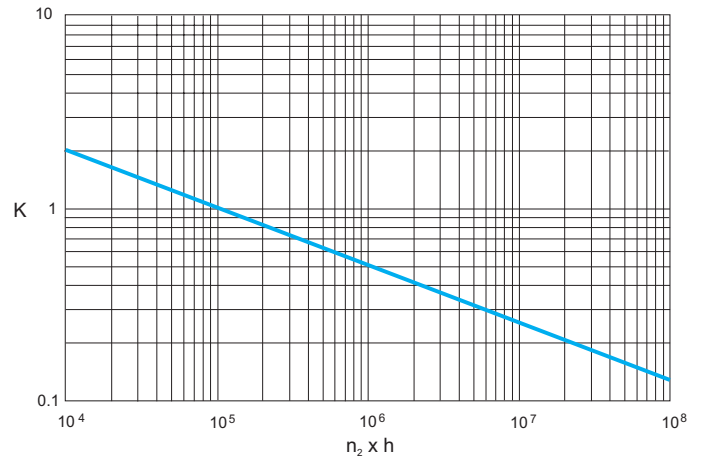
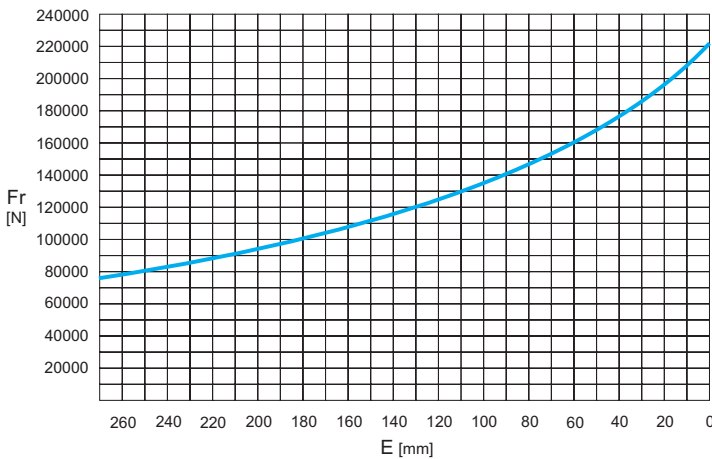

	$n \times h$				
	10^5	10^4	10^6	10^7	10^8
M	Fr			Fr • K	
*CPC	Fr • 0.75			Fr • K • 0.75	

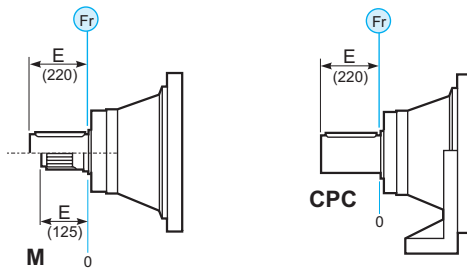

CARICHI ASSIALI (Fa)

I valori dei carichi assiali indicati in tabella sono riferiti alle versioni e alla direzione di applicazione del carico.

AXIAL LOADS (Fa)

The values of the axial loads in the table refer to the output versions and load direction of application.

AXIALLAST (Fa)

Die dargestellten Werte der Axiallast basieren auf der Version und der applizierten Lastichtung.

CHARGES AXIALES (Fa)

Les valeurs des charges axiales indiquées dans le tableau se réfèrent aux versions et à la direction d'application de la charge.

CARGAS AXIALES (Fa)

Los valores de las cargas axiales indicados en la tabla se refieren a las versiones y a la dirección de aplicación de la carga.

CARGAS AXIAIS (Fa)

Os valores das cargas axiais indicadas na tabela referem-se às versões e à direção de aplicação da carga.

Fa [N]	M	CPC	
	80000	80000	←
120000	120000	→	

