



3500

IT EN DE FR ES PT

	i	Mc [kNm]				n1max [min ⁻¹]	Pt [kW]	Kg				
		n ₂ x h	n ₂ x h	n ₂ x h	n ₂ x h			M	P	CPC	F	FS
		10.000	20.000	50.000	100.000							
PG 3501	4.00	42.37	37.50	31.91	28.25	1500	54	193	—	254	157	165
	4.71	36.11	31.96	27.20	24.07							
PG 3502	14.2	42.37	37.50	31.91	28.25	2000	34	243	—	304	207	215
	17.1	42.37	37.50	31.91	28.25							
	20.2	36.11	31.96	27.20	24.07							
	22.4	42.37	37.50	31.91	28.25							
	26.4	36.11	31.96	27.20	24.07							
	31.8	36.11	31.96	27.20	24.07							
	40.8	36.11	31.96	27.20	24.07							
PG 3503	53.7	42.37	37.50	31.91	28.25	2800	23	259	—	320	223	231
	58.7	42.37	37.50	31.91	28.25							
	64.8	42.37	37.50	31.91	28.25							
	70.7	42.37	37.50	31.91	28.25							
	83.2	36.11	31.96	27.20	24.07							
	88.6	42.37	37.50	31.91	28.25							
	99.6	36.11	31.96	27.20	24.07							
	108.7	36.11	31.96	27.20	24.07							
	121.0	36.11	31.96	27.20	24.07							
	136.2	36.11	31.96	27.20	24.07							
	158.1	36.11	31.96	27.20	24.07							
	164.1	36.11	31.96	27.20	24.07							
	191.1	36.11	31.96	27.20	24.07							
	230.3	36.11	31.96	27.20	24.07							
PG 3504	191.0	42.37	37.50	31.91	28.25	2800	17	267	—	328	231	239
	208.6	42.37	37.50	31.91	28.25							
	230.3	42.37	37.50	31.91	28.25							
	251.4	42.37	37.50	31.91	28.25							
	277.6	42.37	37.50	31.91	28.25							
	303.1	42.37	37.50	31.91	28.25							
	328.5	42.37	37.50	31.91	28.25							
	362.7	42.37	37.50	31.91	28.25							
	379.6	42.37	37.50	31.91	28.25							
	437.1	42.37	37.50	31.91	28.25							
	496.0	42.37	37.50	31.91	28.25							
	583.5	36.11	31.96	27.20	24.07							
	677.7	36.11	31.96	27.20	24.07							
	703.4	36.11	31.96	27.20	24.07							
	762.5	36.11	31.96	27.20	24.07							
	816.8	36.11	31.96	27.20	24.07							
	987.0	36.11	31.96	27.20	24.07							
	1067.3	36.11	31.96	27.20	24.07							
	1289.7	36.11	31.96	27.20	24.07							



	i	Mc [kNm]				n1max [min ⁻¹]	Pt [kW]	Kg				
		n ₂ x h	n ₂ x h	n ₂ x h	n ₂ x h			M	P	CPC	F	FS
		10.000	20.000	50.000	100.000							
PGA 3502	12.3	42.37	37.50	31.91	28.25	2000	34	285	—	346	248	256
	14.5	36.11	31.96	27.20	24.07							
	18.7	42.37	37.50	31.91	28.25							
	22.0	36.11	31.96	27.20	24.07							
PGA 3503	43.7	42.37	37.50	31.91	28.25	2800	23	342	—	403	305	313
	52.7	42.37	37.50	31.91	28.25							
	66.4	42.37	37.50	31.91	28.25							
	80.0	42.37	37.50	31.91	28.25							
	94.1	36.11	31.96	27.20	24.07							
	123.0	36.11	31.96	27.20	24.07							
PGA 3504	185.6	42.37	37.50	31.91	28.25	2800	17	299	—	360	263	271
	202.7	42.37	37.50	31.91	28.25							
	223.7	42.37	37.50	31.91	28.25							
	244.3	42.37	37.50	31.91	28.25							
	292.5	42.37	37.50	31.91	28.25							
	319.4	42.37	37.50	31.91	28.25							
	352.6	42.37	37.50	31.91	28.25							
	385.0	42.37	37.50	31.91	28.25							
	414.8	36.11	31.96	27.20	24.07							
	452.9	36.11	31.96	27.20	24.07							
	542.0	36.11	31.96	27.20	24.07							
	591.8	36.11	31.96	27.20	24.07							
	658.8	36.11	31.96	27.20	24.07							
	741.3	36.11	31.96	27.20	24.07							
	860.9	36.11	31.96	27.20	24.07							
	1037.7	36.11	31.96	27.20	24.07							
1253.8	36.11	31.96	27.20	24.07								



(n₂ x h = 20.000)
M_{max} = M_c x 1.65

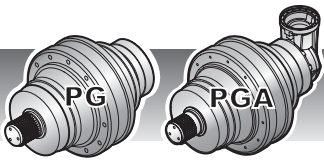

3500

IT EN DE FR ES PT

MS

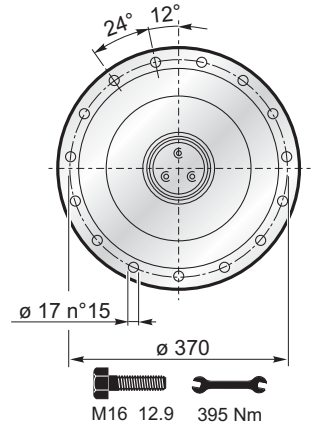
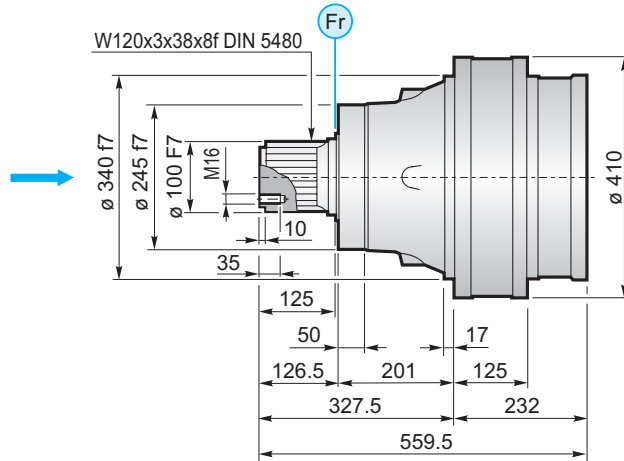
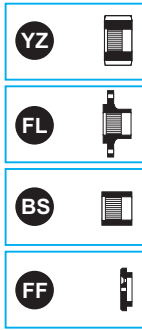

MC

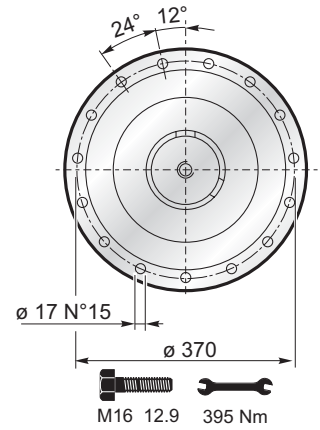
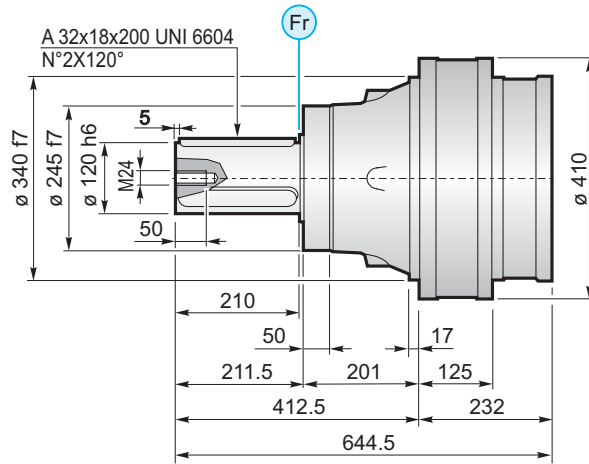

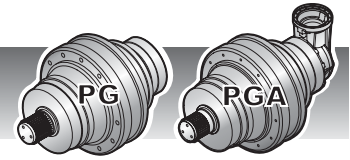

F

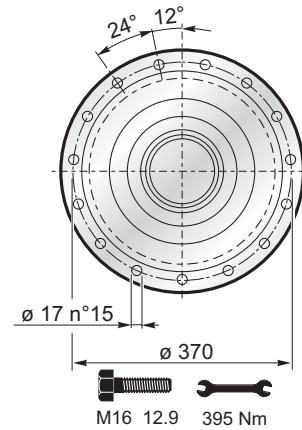
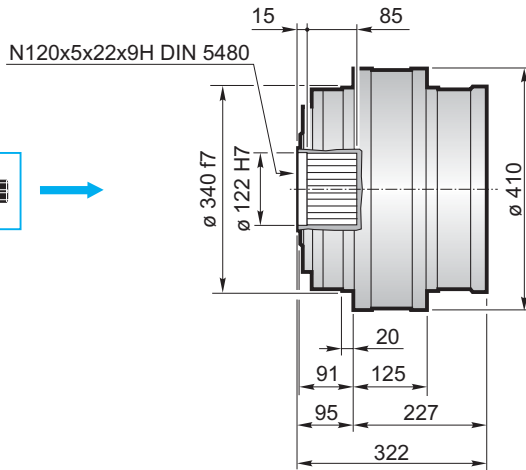

FS

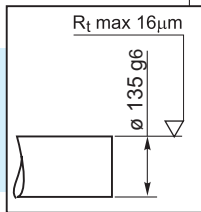
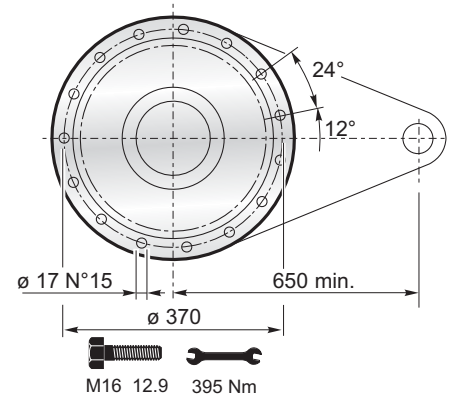
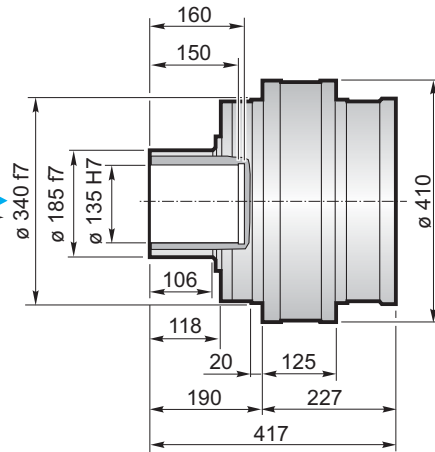

$M_{\text{max}} = 52 \text{ kNm}$

La coppia massima indicata è valida solo con calettatori forniti da Planetary Drives
 The maximum torque indicated is valid only with shrink discs supplied by Planetary Drives
 Das dargestellte, maximale Drehmoment gilt nur mit von Planetary Drives gelieferter Schrumpfscheibe
 Le couple maximal indiqué n'est valable qu'avec les frettes de serrage fournis par Planetary Drives
 El momento máximo indicado sólo es válido con discos de contracción suministrados por Planetary Drives
 O torque máximo indicado é válido exclusivamente com discos de contração fornecidos pela Planetary Drives

CPC

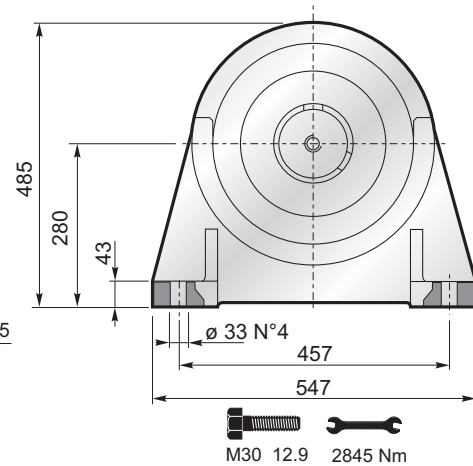
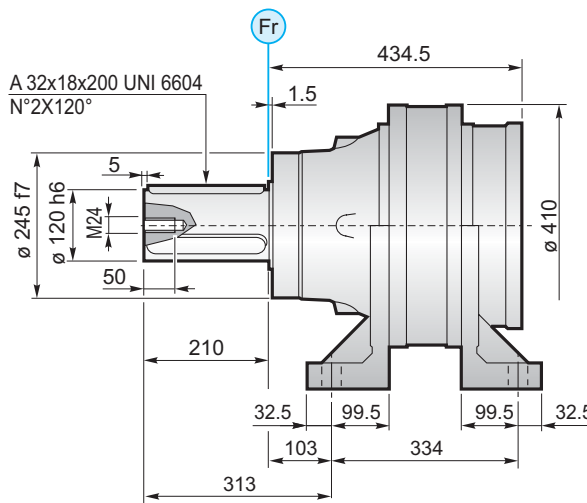

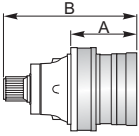

3500

	PG ...MS						
	A	B	RA	RB	EF	EDF	
PG 3501	232	559.5					
PG 3502	319	646.5		•			
PG 3503	390.5	718	•	o	•		
PG 3504	451.5	779	•			•	

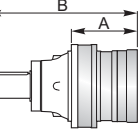
	PG ...MC						
	A	B	RA	RB	EF	EDF	
PG 3501	232	644.5					
PG 3502	319	731.5		•			
PG 3503	390.5	803	•	o	•		
PG 3504	451.5	864	•			•	

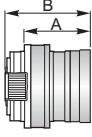
	PG ...F						
	A	B	RA	RB	EF	EDF	
PG 3501	227	322					
PG 3502	314	409		•			
PG 3503	385.5	480.5	•	o	•		
PG 3504	446.5	541.5	•			•	

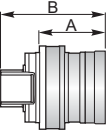
	PG ...FS						
	A	B	RA	RB	EF	EDF	
PG 3501	227	417					
PG 3502	314	504		•			
PG 3503	385.5	575.5	•	o	•		
PG 3504	446.5	636.5	•			•	

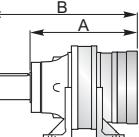
	PG ...CPC						
	A	B	RA	RB	EF	EDF	
PG 3501	434.5	644.5					
PG 3502	521.5	731.5		•			
PG 3503	593	803	•	o	•		
PG 3504	654	864	•			•	

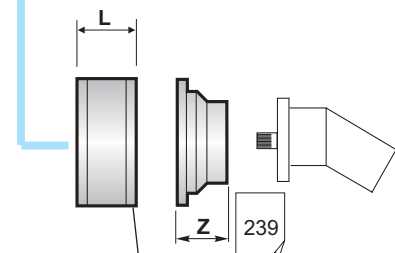
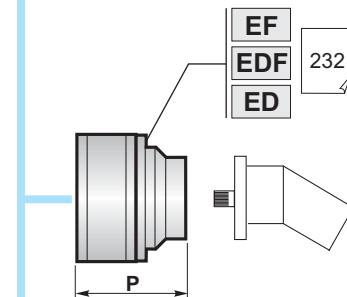
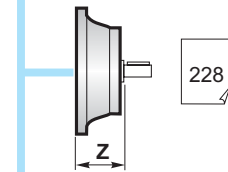
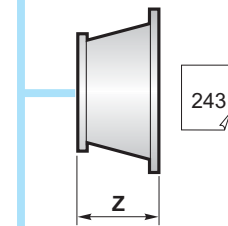
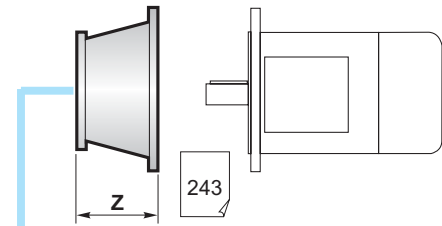

226	RA	RB	RA	L
			RB	81
				125

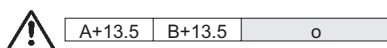



	PGA ...MS					
		A	B	RA	RB	EF
PGA 3502	297	315		•		
PGA 3503	454	240	•	o	•	
PGA 3504	492	240	•		•	

	PGA ...MC					
		A	B	RA	RB	EF
PGA 3502	297	315		•		
PGA 3503	454	240	•	o	•	
PGA 3504	492	240	•		•	

	PGA ...F					
		A	B	RA	RB	EF
PGA 3502	287	315		•		
PGA 3503	444	240	•	o	•	
PGA 3504	482	240	•		•	

	PGA ...FS					
		A	B	RA	RB	EF
PGA 3502	287	315		•		
PGA 3503	444	240	•	o	•	
PGA 3504	482	240	•		•	

	PGA ...CPC					
		A	B	RA	RB	EF
PGA 3502	499.5	315		•		
PGA 3503	656.5	240	•	o	•	
PGA 3504	694.5	240	•		•	

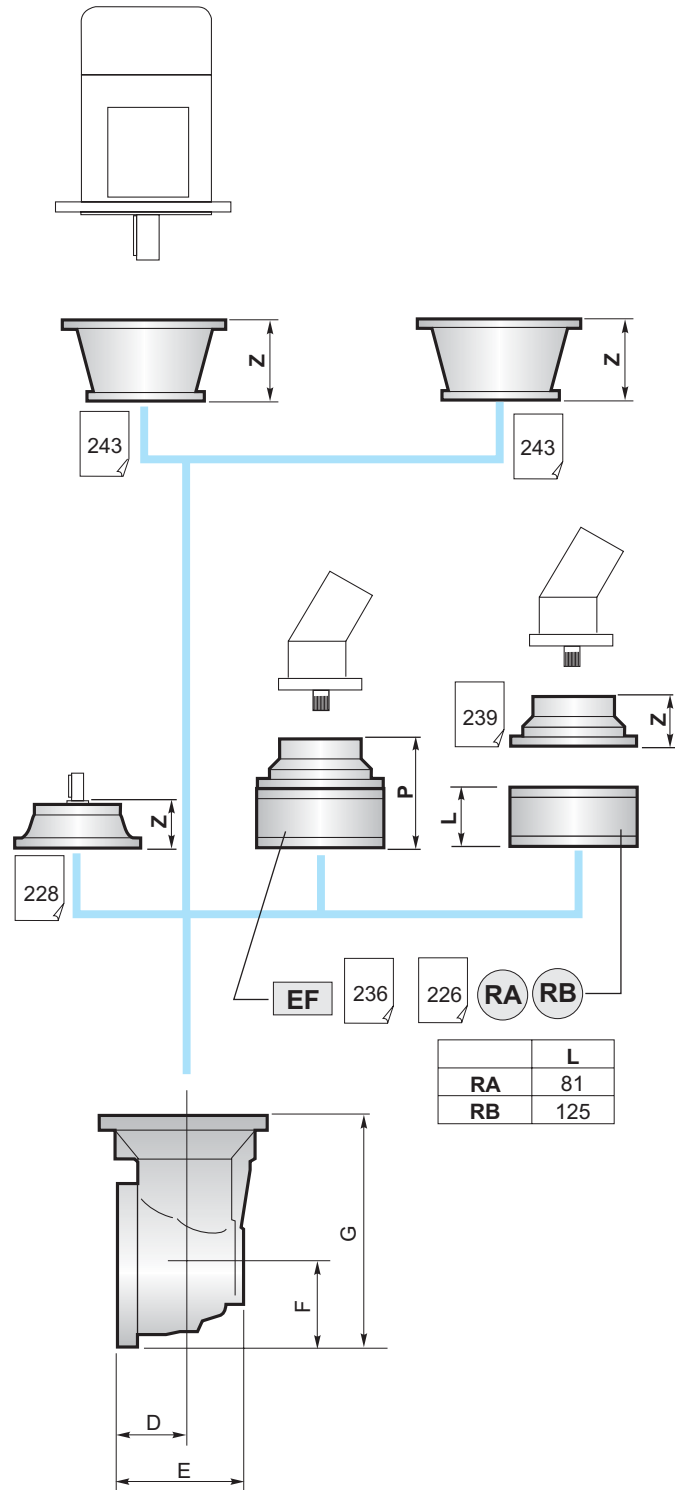

	D	E	F	G
PGA 3502	88	256	235	550
PGA 3503	88	256	235	550
PGA 3504	88	164	140	380

	A	B+16.5	o
--	---	--------	---

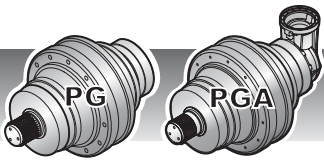

3500

IT EN DE FR ES PT

BS Boccia scanalata / Splined bushing
Innenverzahnte Buchse / Moyeu cannelé
Casquillo ranurado / Bucha estriada

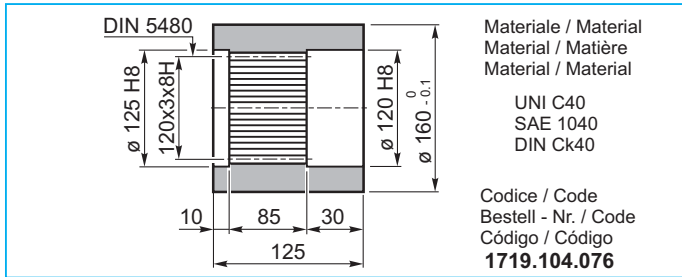

KB Barra scanalata / Splined rod
Außenverzahnte Welle / Arbre cannelé
Barra ranurada / Barra estriada

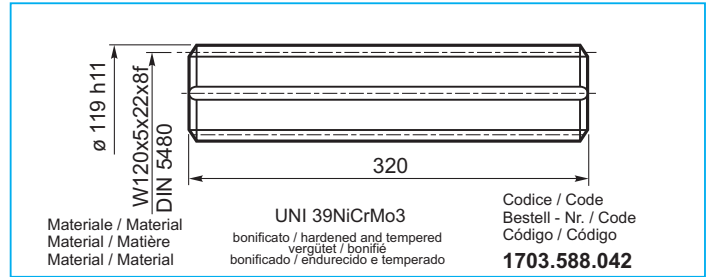

FL Flangia / Flange
Flansch / Bride
Brida / Flange

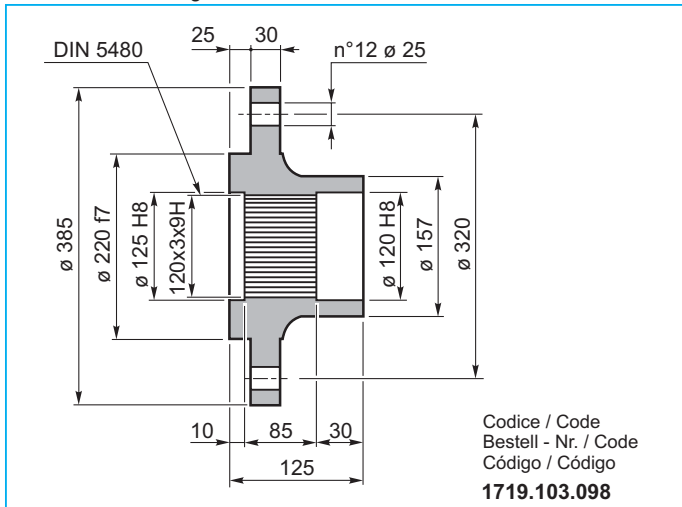

GA Giunto di attrito / Shrink disc
Schrumpfscheibe / Frette de serrage
Disco de contracción / Disco de contração

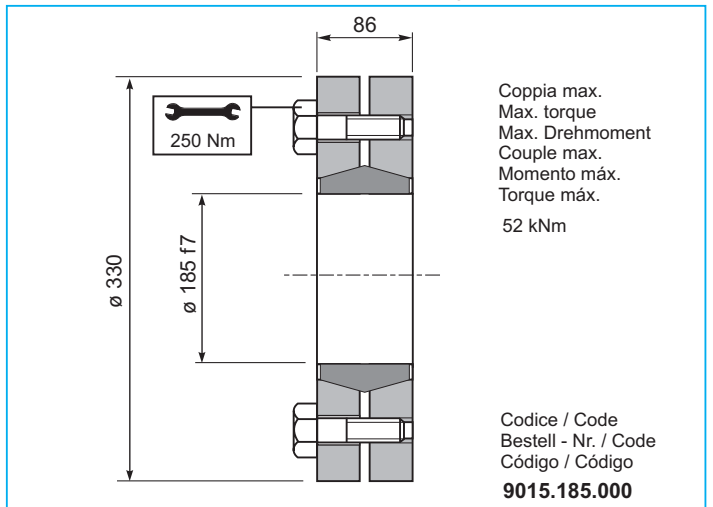

FF Fondello di arresto / Stop bottom plate
Endscheibe / Bouchon de fermeture
Tapón de detención / Fundo de batente

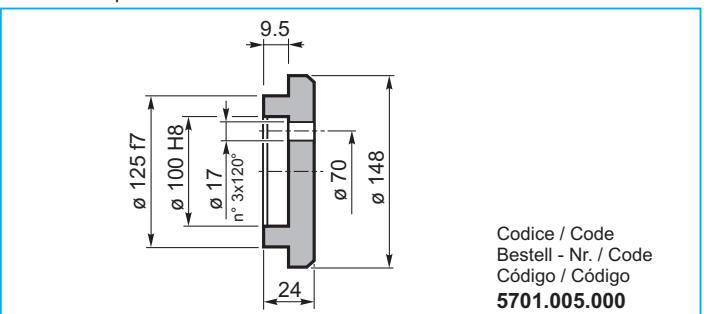

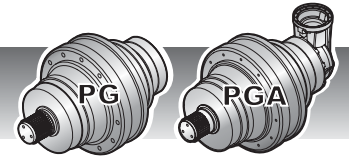

CARICHI RADIALI (Fr)

Nei diagrammi seguenti sono riportati i carichi radiali e i coefficienti K per rapportarli al valore $n_2 \times h$ desiderato.

RADIAL LOADS (Fr)

The following curves show the radial loads and the K factors to obtain the required $n_2 \times h$ value.

RADIALLAST (Fr)

In den nachstehenden Diagrammen ist die Radiallast und der Koeffizient K dargestellt und kann mit dem gewünschten Wert $n_2 \times h$ verglichen werden.

CHARGES RADIALES (Fr)

Dans les diagrammes suivants sont indiqués les charges radiales et les facteurs K de façon à obtenir la valeur $n_2 \times h$ désirée.

CARGAS AXIALES (Fr)

En los siguientes diagramas se indican las cargas radiales y los coeficientes K para obtener el valor requerido $n_2 \times h$.

CARGAS AXIAIS (Fr)

Nos diagramas seguintes são indicadas as cargas radiais e os coeficientes K para obter o valor $n_2 \times h$ desejado.

M - CPC*

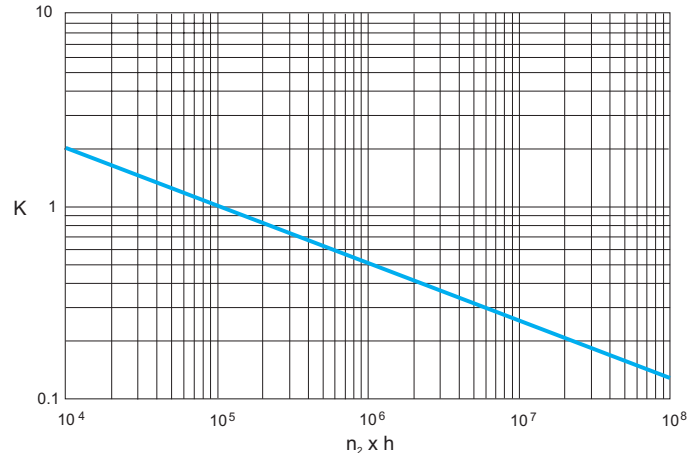
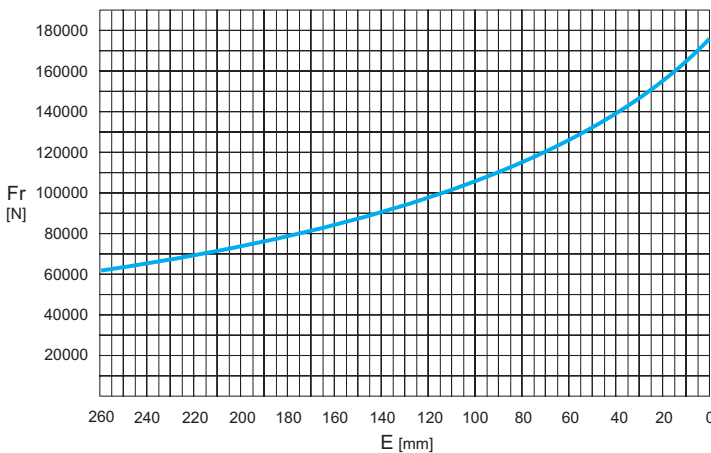

	$n \times h$				
	10^5	10^4	10^6	10^7	10^8
M	Fr		Fr • K		
*CPC	Fr • 0.75		Fr • K • 0.75		

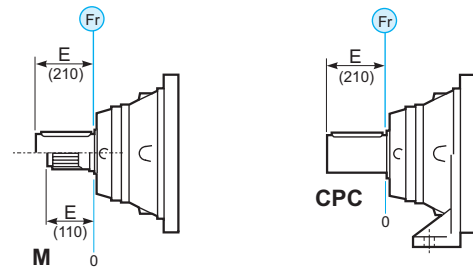

CARICHI ASSIALI (Fa)

I valori dei carichi assiali indicati in tabella sono riferiti alle versioni e alla direzione di applicazione del carico.

AXIAL LOADS (Fa)

The values of the axial loads in the table refer to the output versions and load direction of application.

AXIALLAST (Fa)

Die dargestellten Werte der Axiallast basieren auf der Version und der applizierten Lastrichtung.

CHARGES AXIALES (Fa)

Les valeurs des charges axiales indiquées dans le tableau se réfèrent aux versions et à la direction d'application de la charge.

CARGAS AXIALES (Fa)

Los valores de las cargas axiales indicados en la tabla se refieren a las versiones y a la dirección de aplicación de la carga.

CARGAS AXIAIS (Fa)

Os valores das cargas axiais indicadas na tabela referem-se às versões e à direção de aplicação da carga.

Fa [N]	M	CPC	← →
		80000	
	100000	100000	

