



3000



	i	Mc [kNm]				n1max [min ⁻¹]	Pt [kW]	Kg				
		n ₂ x h	n ₂ x h	n ₂ x h	n ₂ x h			M	P	CPC	F	FS
		10.000	20.000	50.000	100.000							
PG 3002	14.2	34.75	30.76	26.18	23.17	2000	34	237	—	298	196	204
	17.1	34.75	30.76	26.18	23.17							
	22.4	34.75	30.76	26.18	23.17							
	29.1	26.87	23.78	20.24	17.91							
	35.1	26.87	23.78	20.24	17.91							
PG 3003	64.6	34.75	30.76	26.18	23.17	2800	23	253	—	314	212	220
	73.5	34.75	30.76	26.18	23.17							
	88.6	34.75	30.76	26.18	23.17							
	102.9	34.75	30.76	26.18	23.17							
	124.3	34.75	30.76	26.18	23.17							
	134.4	34.75	30.76	26.18	23.17							
PG 3004	251.4	34.75	30.76	26.18	23.17	2800	17	261	—	322	220	228
	300.9	34.75	30.76	26.18	23.17							
	314.9	34.75	30.76	26.18	23.17							
	328.5	34.75	30.76	26.18	23.17							
	362.6	34.75	30.76	26.18	23.17							
	379.6	34.75	30.76	26.18	23.17							
	396.0	34.75	30.76	26.18	23.17							
	427.0	34.75	30.76	26.18	23.17							
	477.3	34.75	30.76	26.18	23.17							
	517.4	34.75	30.76	26.18	23.17							
	576.0	34.75	30.76	26.18	23.17							
	623.7	34.75	30.76	26.18	23.17							
	694.3	34.75	30.76	26.18	23.17							
	752.6	34.75	30.76	26.18	23.17							
	838.9	34.75	30.76	26.18	23.17							
	1015.5	26.87	23.78	20.24	17.91							
1425.0	26.87	23.78	20.24	17.91								



	i	Mc [kNm]				n1max [min ⁻¹]	Pt [kW]	Kg				
		n ₂ x h	n ₂ x h	n ₂ x h	n ₂ x h			M	P	CPC	F	FS
		10.000	20.000	50.000	100.000							
PGA 3003	52.7	34.75	30.76	26.18	23.17	2800	23	336	—	397	299	307
	66.4	34.75	30.76	26.18	23.17							
	80.0	34.75	30.76	26.18	23.17							
	104.5	34.75	30.76	26.18	23.17							
	135.9	26.87	23.78	20.24	17.91							
	163.8	26.87	23.78	20.24	17.91							
PGA 3004	306.0	34.75	30.76	26.18	23.17	2800	17	293	—	354	252	260
	352.6	34.75	30.76	26.18	23.17							
	385.0	34.75	30.76	26.18	23.17							
	460.7	34.75	30.76	26.18	23.17							
	519.8	26.87	23.78	20.24	17.91							
	598.9	26.87	23.78	20.24	17.91							
	676.7	34.75	30.76	26.18	23.17							
	729.3	26.87	23.78	20.24	17.91							
	819.1	26.87	23.78	20.24	17.91							
	951.2	26.87	23.78	20.24	17.91							
	1385.5	26.87	23.78	20.24	17.91							



(n₂ x h = 20.000)

$$M_{\max} = M_c \times 2$$

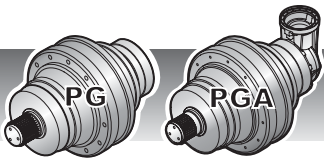

3000

IT EN DE FR ES PT

MS

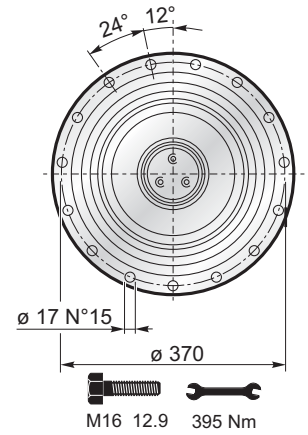
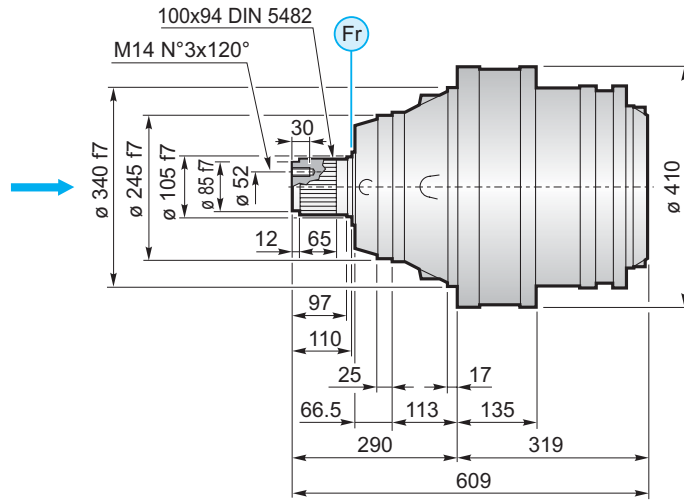
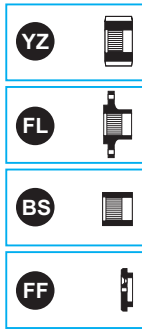

MC

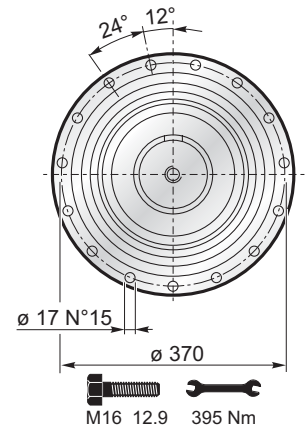
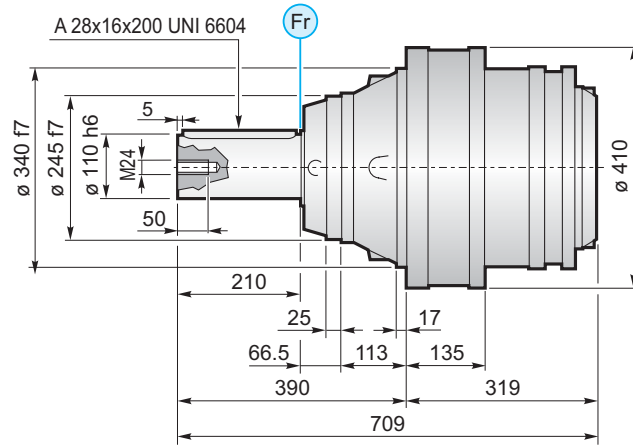

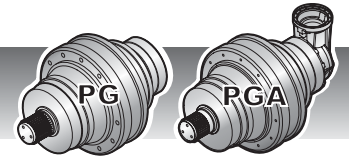

F

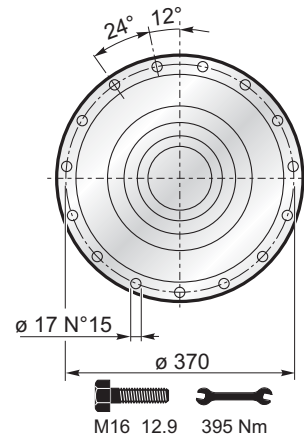
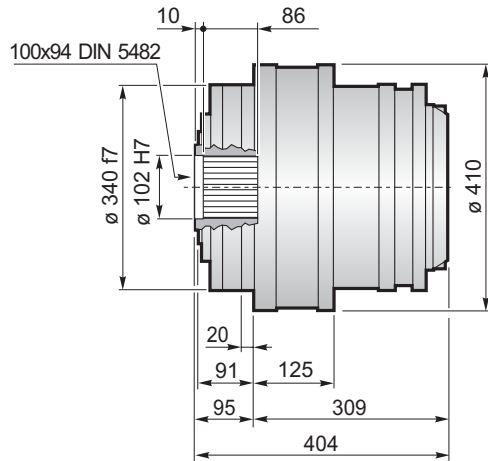
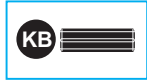

FS

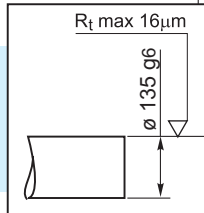
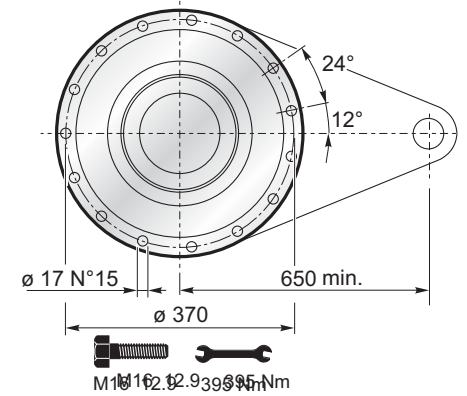
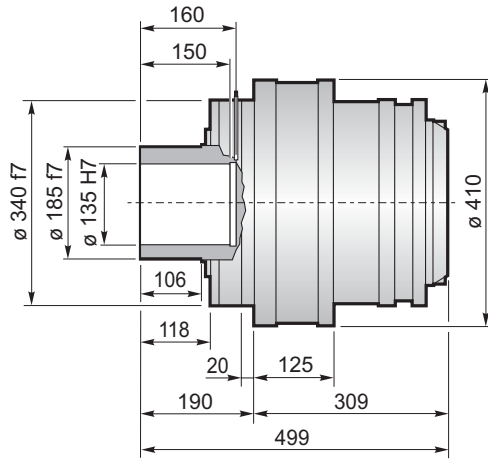

$M_{max} = 52 \text{ kNm}$

La coppia massima indicata è valida solo con calettatori forniti da Planetary Drives
 The maximum torque indicated is valid only with shrink discs supplied by Planetary Drives
 Das dargestellte, maximale Drehmoment gilt nur mit von Planetary Drives gelieferter Schrumpfscheibe
 Le couple maximal indiqué n'est valable qu'avec les frettes de serrage fournis par Planetary Drives
 El momento máximo indicado sólo es válido con discos de contracción suministrados por Planetary Drives
 O torque máximo indicado é válido exclusivamente com discos de contração fornecidos pela Planetary Drives

CPC

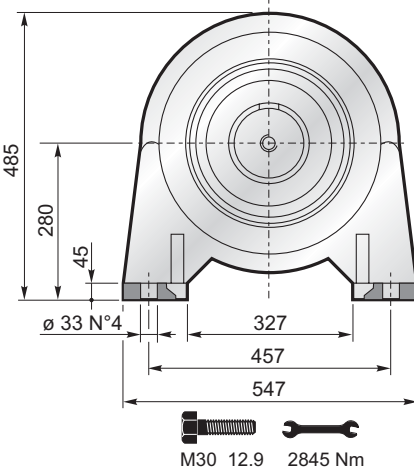
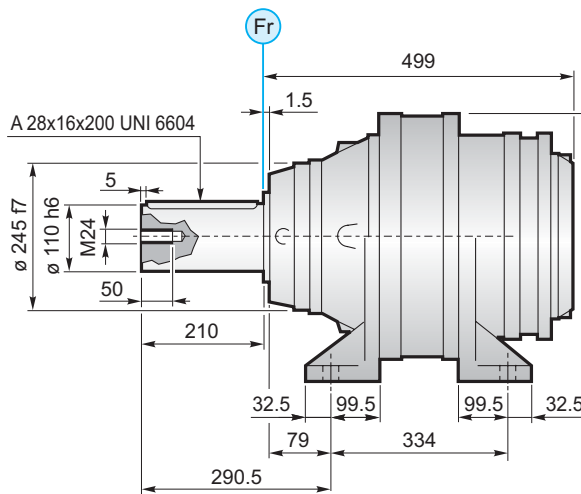

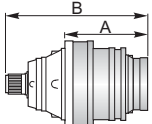

3000

	PG ...MS						
	A	B	RA	RB	EF	EDF	
PG 3002	319	609		•			
PG 3003	390.5	680.5	•	o	•		
PG 3004	451.5	741.5	•			•	

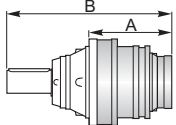
	PG ...MC						
	A	B	RA	RB	EF	EDF	
PG 3002	319	709		•			
PG 3003	390.5	780.5	•	o	•		
PG 3004	451.5	841.5	•			•	

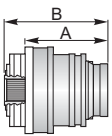
	PG ...F						
	A	B	RA	RB	EF	EDF	
PG 3002	309	404		•			
PG 3003	380.5	475.5	•	o	•		
PG 3004	441.5	536.5	•			•	

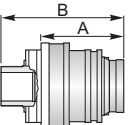
	PG ...FS						
	A	B	RA	RB	EF	EDF	
PG 3002	309	499		•			
PG 3003	380.5	570.5	•	o	•		
PG 3004	441.5	631.5	•			•	

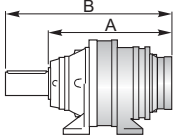
	PG ...CPC						
	A	B	RA	RB	EF	EDF	
PG 3002	499	709		•			
PG 3003	570.5	780.5	•	o	•		
PG 3004	631.5	841.5	•			•	

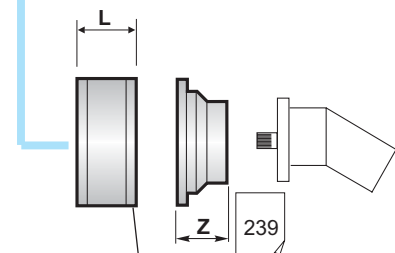
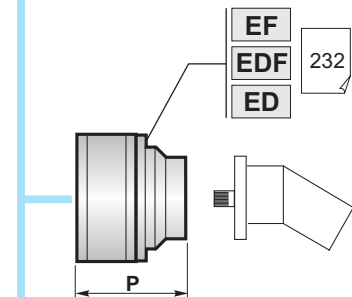
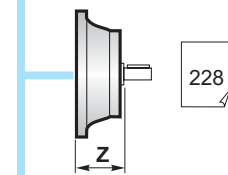
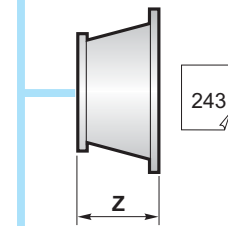
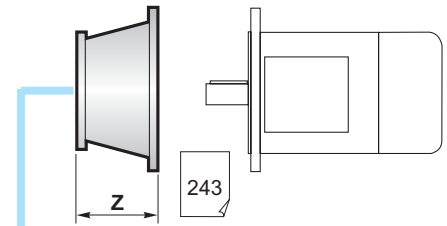

226	RA	RB	L
	RA		81
	RB		125

!	A+13.5	B+13.5	o
---	--------	--------	---



	PGA ...MS					
		A	B	RA	RB	EF
	PGA 3003	407	240	•	o	•
PGA 3004	478.5	240	•	o	•	

	PGA ...MC					
		A	B	RA	RB	EF
	PGA 3003	407	240	•	o	•
PGA 3004	478.5	240	•	o	•	

	PGA ...F					
		A	B	RA	RB	EF
	PGA 3003	397	240	•	o	•
PGA 3004	468.5	240	•	o	•	

	PGA ...FS					
		A	B	RA	RB	EF
	PGA 3003	397	240	•	o	•
PGA 3004	468.5	240	•	o	•	

	PGA ...CPC					
		A	B	RA	RB	EF
	PGA 3003	585.5	240	•	o	•
PGA 3004	657	240	•	o	•	

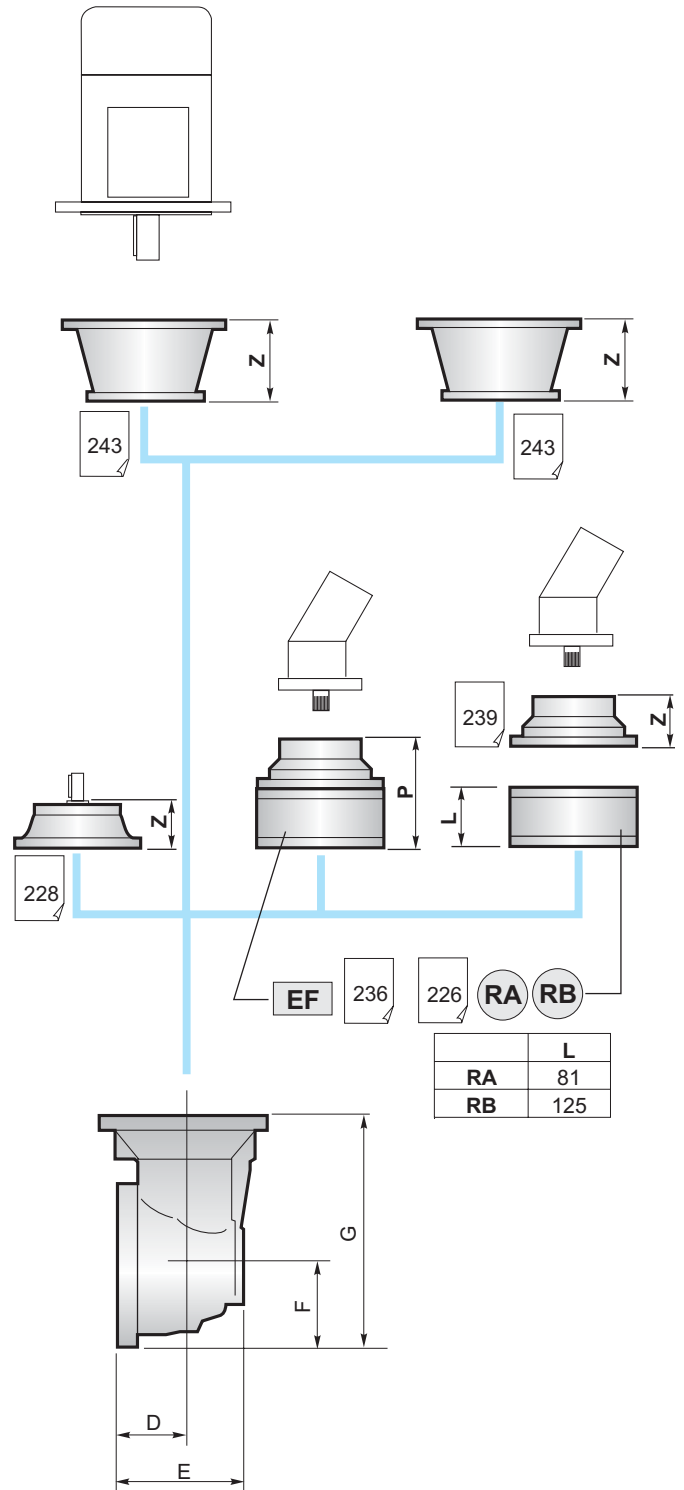

	L
RA	81
RB	125

	D	E	F	G
PGA 3003	88	164	140	380
PGA 3004	88	164	140	380

	A+16.5	B	o
--	--------	---	---

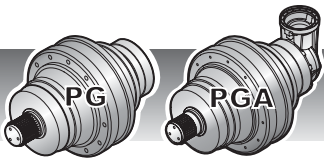

3000

IT EN DE FR ES PT

BS Boccola scanalata / Splined bushing
Innenverzahnte Buchse / Moyeu cannelé
Casquillo ranurado / Bucha estriada

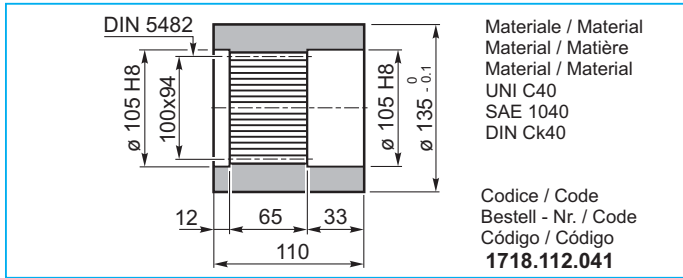

KB Barra scanalata / Splined rod
Außenverzahnte Welle / Arbre cannelé
Barra ranurada / Barra estriada

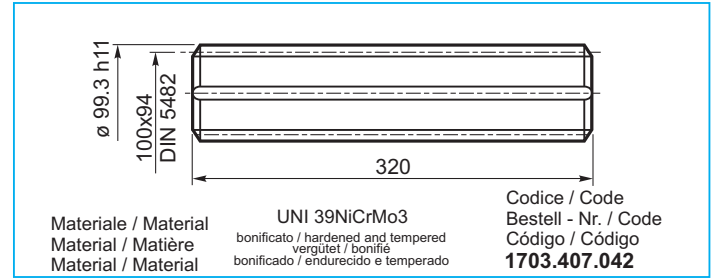

FL Flangia / Flange
Flansch / Bride
Brida / Flange

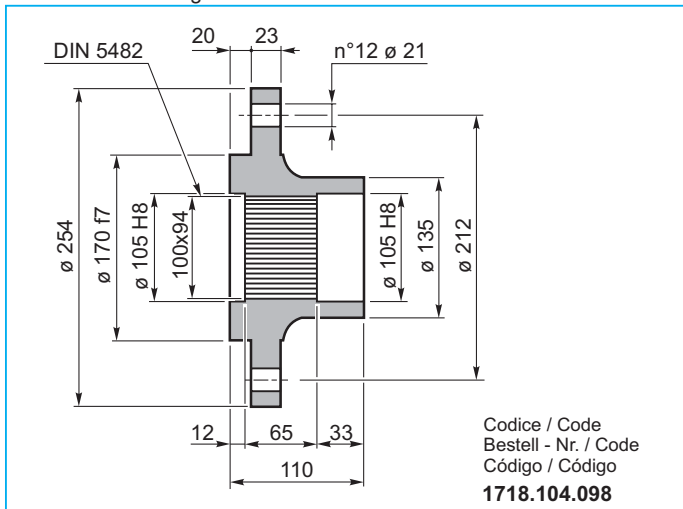

GA Giunto di attrito / Shrink disc
Schrumpfscheibe / Frette de serrage
Disco de contracción / Disco de contração

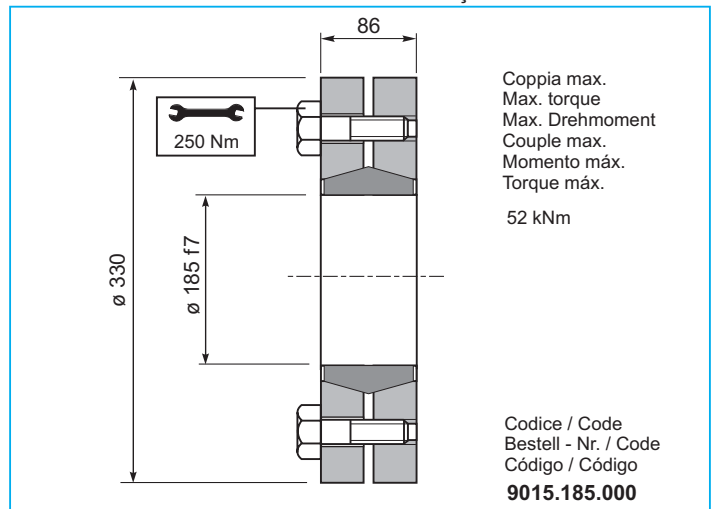

FF Fondello di arresto / Stop bottom plate
Endscheibe / Bouchon de fermeture
Tapón de detención / Fundo de batente

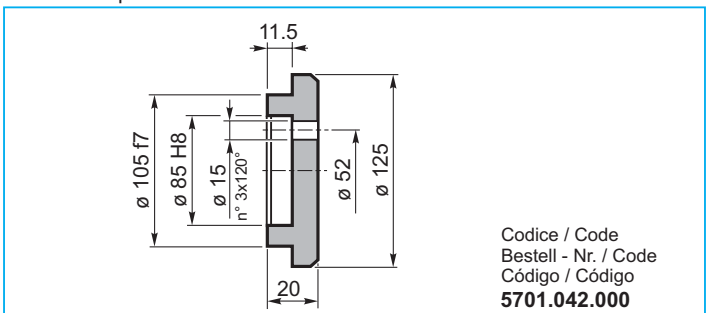

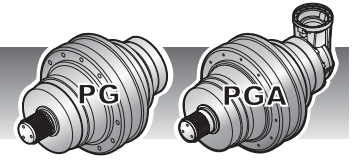

CARICHI RADIALI (Fr)

Nei diagrammi seguenti sono riportati i carichi radiali e i coefficienti K per rapportarli al valore $n_2 \times h$ desiderato.

RADIAL LOADS (Fr)

The following curves show the radial loads and the K factors to obtain the required $n_2 \times h$ value.

RADIALLAST (Fr)

In den nachstehenden Diagrammen ist die Radiallast und der Koeffizient K dargestellt und kann mit dem gewünschten Wert $n_2 \times h$ verglichen werden.

CHARGES RADIALES (Fr)

Dans les diagrammes suivants sont indiqués les charges radiales et les facteurs K de façon à obtenir la valeur $n_2 \times h$ désirée.

CARGAS AXIALES (Fr)

En los siguientes diagramas se indican las cargas radiales y los coeficientes K para obtener el valor requerido $n_2 \times h$.

CARGAS AXIAIS (Fr)

Nos diagramas seguintes são indicadas as cargas radiais e os coeficientes K para obter o valor $n_2 \times h$ desejado.

M - CPC*

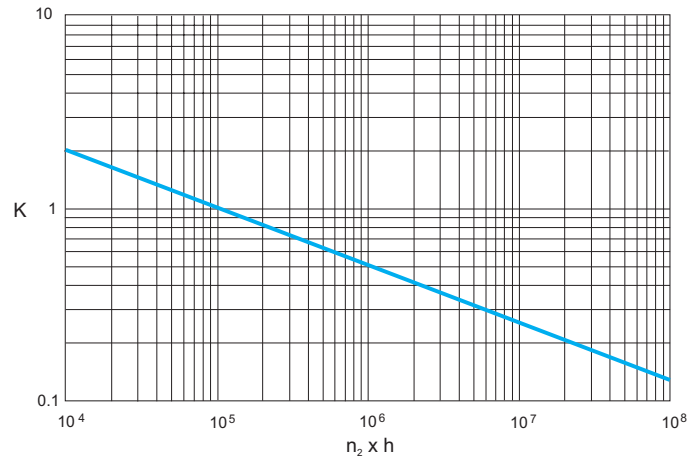
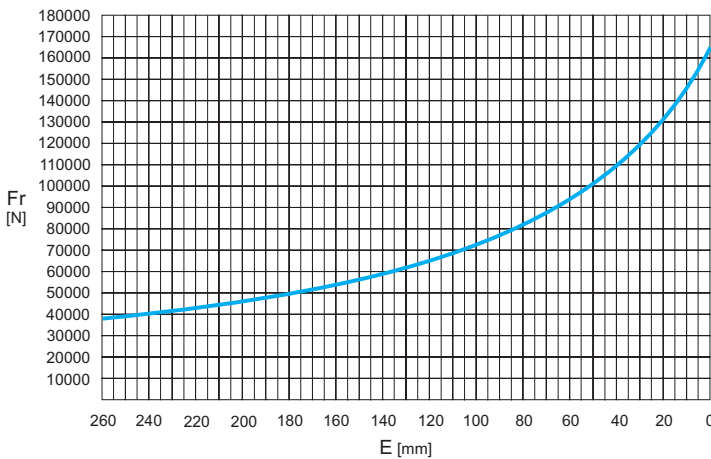

	$n \times h$				
	10^5	10^4	10^6	10^7	10^8
M	Fr				Fr • K
*CPC	Fr • 0.75				Fr • K • 0.75

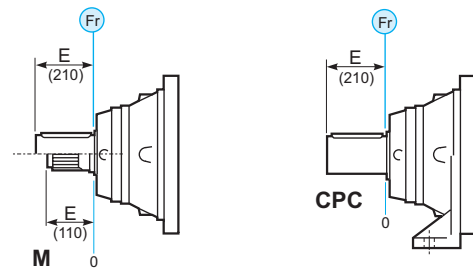

CARICHI ASSIALI (Fa)

I valori dei carichi assiali indicati in tabella sono riferiti alle versioni e alla direzione di applicazione del carico.

AXIAL LOADS (Fa)

The values of the axial loads in the table refer to the output versions and load direction of application.

AXIALLAST (Fa)

Die dargestellten Werte der Axiallast basieren auf der Version und der applizierten Lastrichtung.

CHARGES AXIALES (Fa)

Les valeurs des charges axiales indiquées dans le tableau se réfèrent aux versions et à la direction d'application de la charge.

CARGAS AXIALES (Fa)

Los valores de las cargas axiales indicados en la tabla se refieren a las versiones y a la dirección de aplicación de la carga.

CARGAS AXIAIS (Fa)

Os valores das cargas axiais indicadas na tabela referem-se às versões e à direção de aplicação da carga.

Fa [N]	M	CPC	
		75000	75000
	95000	95000	→

