



160

	i	M _c [kNm]				n _{1max} [min ⁻¹]	Pt [kW]	Kg				
		n ₂ x h	n ₂ x h	n ₂ x h	n ₂ x h			M	P	CPC	F	FS
		10.000	20.000	50.000	100.000							
PG 161	3.55	1.92	1.70	1.45	1.28	2800	12	15	17	20	13	16
	4.28	1.92	1.70	1.45	1.28							
	5.60	1.37	1.21	1.03	0.91							
	6.75	1.13	1.00	0.85	0.75							
PG 162	12.6	1.92	1.70	1.45	1.28	2800	8	21	23	26	19	22
	15.2	1.92	1.70	1.45	1.28							
	19.9	1.92	1.70	1.45	1.28							
	23.9	1.92	1.70	1.45	1.28							
	28.9	1.92	1.70	1.45	1.28							
	31.4	1.37	1.21	1.03	0.91							
	37.8	1.37	1.21	1.03	0.91							
	45.5	1.13	1.00	0.85	0.75							
	58.5	1.13	1.00	0.85	0.75							
	PG 163	54.1	1.92	1.70	1.45							
65.3		1.92	1.70	1.45	1.28							
70.7		1.92	1.70	1.45	1.28							
78.7		1.92	1.70	1.45	1.28							
85.3		1.92	1.70	1.45	1.28							
102.8		1.92	1.70	1.45	1.28							
111.5		1.92	1.70	1.45	1.28							
134.3		1.92	1.70	1.45	1.28							
161.9		1.92	1.70	1.45	1.28							
172.5		1.92	1.70	1.45	1.28							
207.9		1.92	1.70	1.45	1.28							
211.6		1.37	1.21	1.03	0.91							
255.1		1.37	1.21	1.03	0.91							
271.7		1.37	1.21	1.03	0.91							
307.5		1.13	1.00	0.85	0.75							
327.5		1.37	1.21	1.03	0.91							
394.8	1.13	1.00	0.85	0.75								
PG 164	337.3	1.92	1.70	1.45	1.28	2800	1.5	33	35	38	31	34
	365.7	1.92	1.70	1.45	1.28							
	396.4	1.92	1.70	1.45	1.28							
	440.8	1.92	1.70	1.45	1.28							
	477.8	1.92	1.70	1.45	1.28							
	531.3	1.92	1.70	1.45	1.28							
	575.9	1.92	1.70	1.45	1.28							
	624.4	1.92	1.70	1.45	1.28							
	694.2	1.92	1.70	1.45	1.28							
	752.6	1.92	1.70	1.45	1.28							
	836.8	1.92	1.70	1.45	1.28							
	907.1	1.92	1.70	1.45	1.28							
	966.3	1.92	1.70	1.45	1.28							
	1093.4	1.92	1.70	1.45	1.28							
	1144.5	1.92	1.70	1.45	1.28							
	1185.4	1.37	1.21	1.03	0.91							
	1318.0	1.92	1.70	1.45	1.28							
	1428.8	1.37	1.21	1.03	0.91							
	1692.3	1.92	1.70	1.45	1.28							
3422.1	1.13	1.00	0.85	0.75								



	i	Mc [kNm]				n1max [min ⁻¹]	Pt [kW]	Kg				
		n ₂ x h	n ₂ x h	n ₂ x h	n ₂ x h			M	P	CPC	F	FS
		10.000	20.000	50.000	100.000							
PGA 162	10.4	1.92	1.70	1.45	1.28	2800	8	30	32	35	28	31
	12.5	1.92	1.70	1.45	1.28							
	16.4	1.37	1.21	1.03	0.91							
	19.7	1.13	1.00	0.85	0.75							
PGA 163	37.0	1.92	1.70	1.45	1.28	2800	5	36	38	41	34	37
	44.6	1.92	1.70	1.45	1.28							
	53.8	1.92	1.70	1.45	1.28							
	58.4	1.92	1.70	1.45	1.28							
	70.3	1.92	1.70	1.45	1.28							
	84.8	1.92	1.70	1.45	1.28							
	91.9	1.37	1.21	1.03	0.91							
	110.8	1.37	1.21	1.03	0.91							
	133.6	1.13	1.00	0.85	0.75							
	171.5	1.13	1.00	0.85	0.75							
PGA 164	131.8	1.92	1.70	1.45	1.28	2800	1.5	42	44	47	40	43
	158.9	1.92	1.70	1.45	1.28							
	191.5	1.92	1.70	1.45	1.28							
	207.6	1.92	1.70	1.45	1.28							
	230.8	1.92	1.70	1.45	1.28							
	301.7	1.92	1.70	1.45	1.28							
	327.0	1.92	1.70	1.45	1.28							
	363.6	1.92	1.70	1.45	1.28							
	394.2	1.92	1.70	1.45	1.28							
	475.1	1.92	1.70	1.45	1.28							
	515.3	1.37	1.21	1.03	0.91							
	572.7	1.92	1.70	1.45	1.28							
	610.1	1.92	1.70	1.45	1.28							
	735.4	1.92	1.70	1.45	1.28							
	797.2	1.37	1.21	1.03	0.91							
	960.9	1.37	1.21	1.03	0.91							
	1158.2	1.13	1.00	0.85	0.75							
	1233.7	1.37	1.21	1.03	0.91							
1487.1	1.13	1.00	0.85	0.75								



(n₂ x h = 20.000)
 $M_{max} = M_c \times 2$

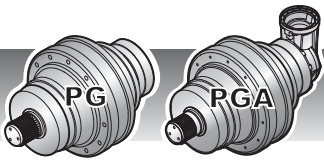

160

MS

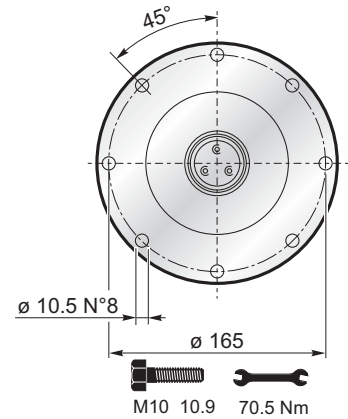
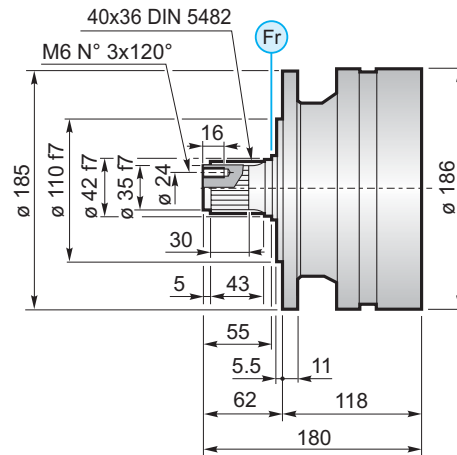
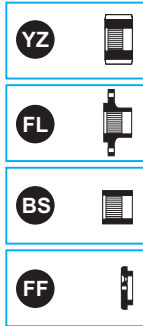

MC

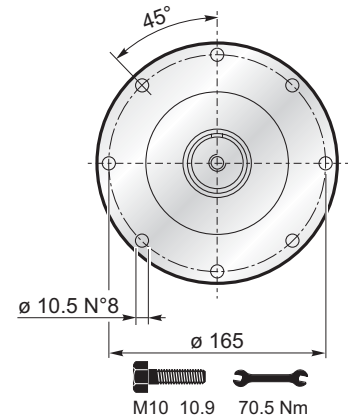
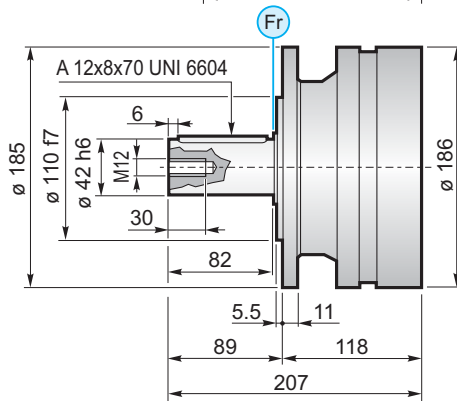

PS

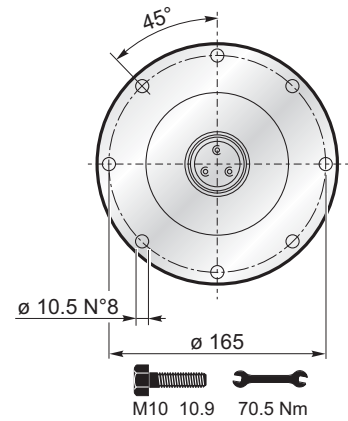
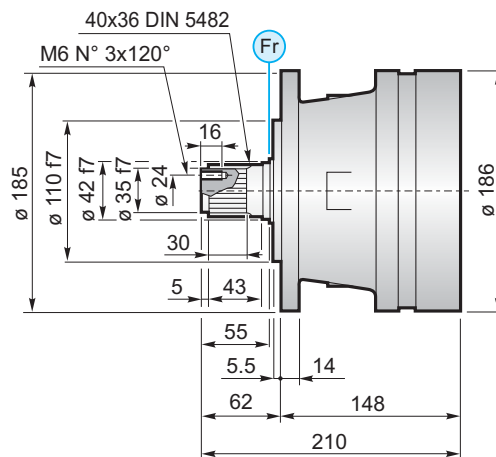
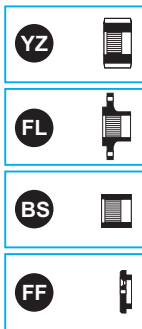

PC

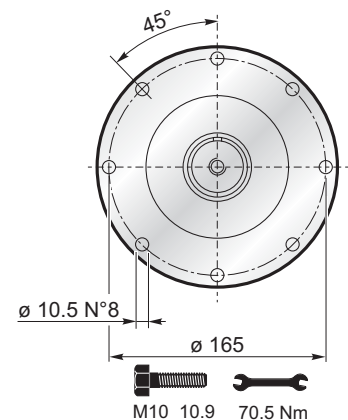
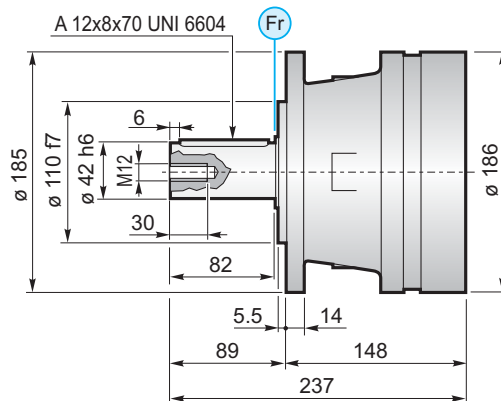

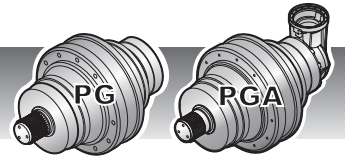

F

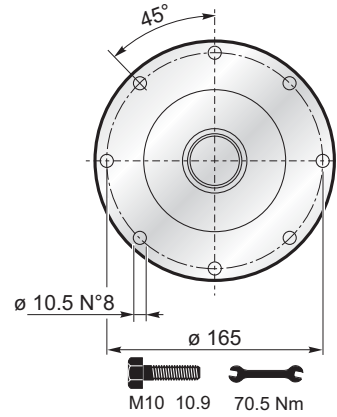
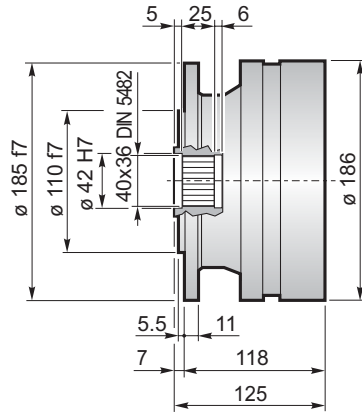
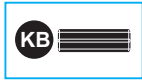

FS

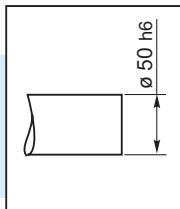
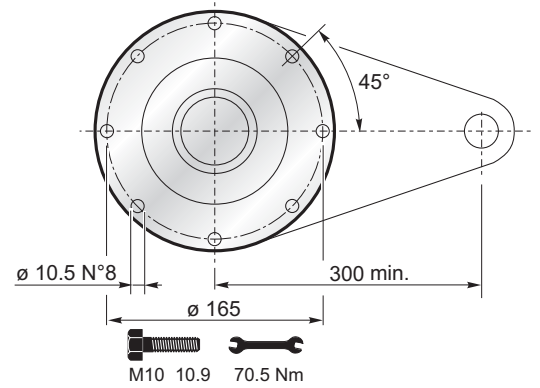
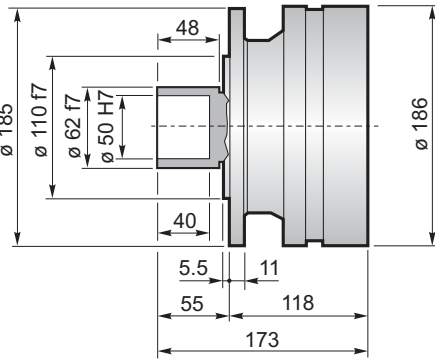

$M_{max} = 2.2 \text{ kNm}$

La coppia massima indicata è valida solo con calettatori forniti da Planetary Drives
 The maximum torque indicated is valid only with shrink discs supplied by Planetary Drives
 Das dargestellte, maximale Drehmoment gilt nur mit von Planetary Drives gelieferter Schrumpfscheibe
 Le couple maximal indiqué n'est valable qu'avec les frettes de serrage fournis par Planetary Drives
 El momento máximo indicado sólo es válido con discos de contracción suministrados por Planetary Drives
 O torque máximo indicado é válido exclusivamente com discos de contração fornecidos pela Planetary Drives

CPC

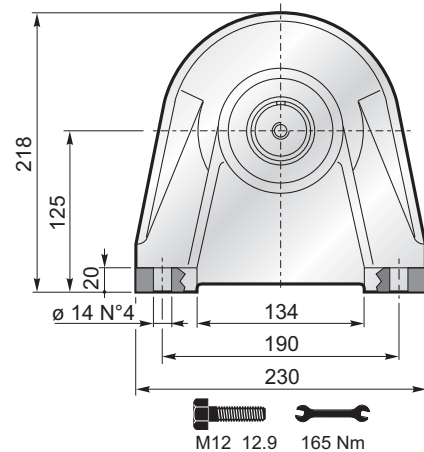
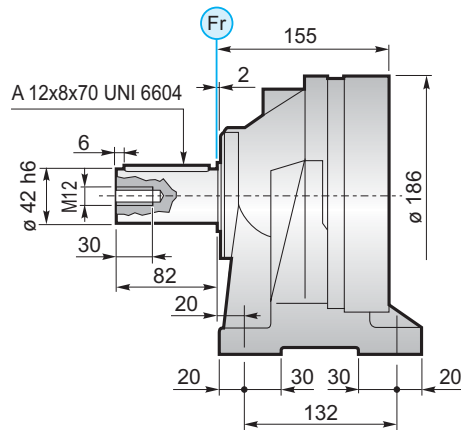

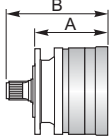

160

	PG ...MS					
	A	B	RA	RB	EF	EDF
PG 161	118	180	•			•
PG 162	166	228	•			•
PG 163	214	276	•			•
PG 164	262	324	•			•

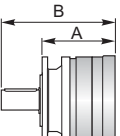
	PG ...MC					
	A	B	RA	RB	EF	EDF
PG 161	118	207	•			•
PG 162	166	255	•			•
PG 163	214	303	•			•
PG 164	262	351	•			•

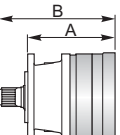
	PG ...PS					
	A	B	RA	RB	EF	EDF
PG 161	148	210	•			•
PG 162	196	258	•			•
PG 163	244	306	•			•
PG 164	292	354	•			•

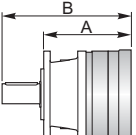
	PG ...PC					
	A	B	RA	RB	EF	EDF
PG 161	148	237	•			•
PG 162	196	285	•			•
PG 163	244	333	•			•
PG 164	292	381	•			•

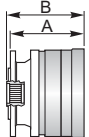
	PG ...F					
	A	B	RA	RB	EF	EDF
PG 161	118	125	•			•
PG 162	166	173	•			•
PG 163	214	221	•			•
PG 164	262	269	•			•

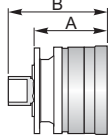
	PG ...FS					
	A	B	RA	RB	EF	EDF
PG 161	118	173	•			•
PG 162	166	221	•			•
PG 163	214	269	•			•
PG 164	262	317	•			•

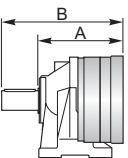
	PG ...CPC					
	A	B	RA	RB	EF	EDF
PG 161	148	237	•			•
PG 162	196	285	•			•
PG 163	244	333	•			•
PG 164	292	381	•			•

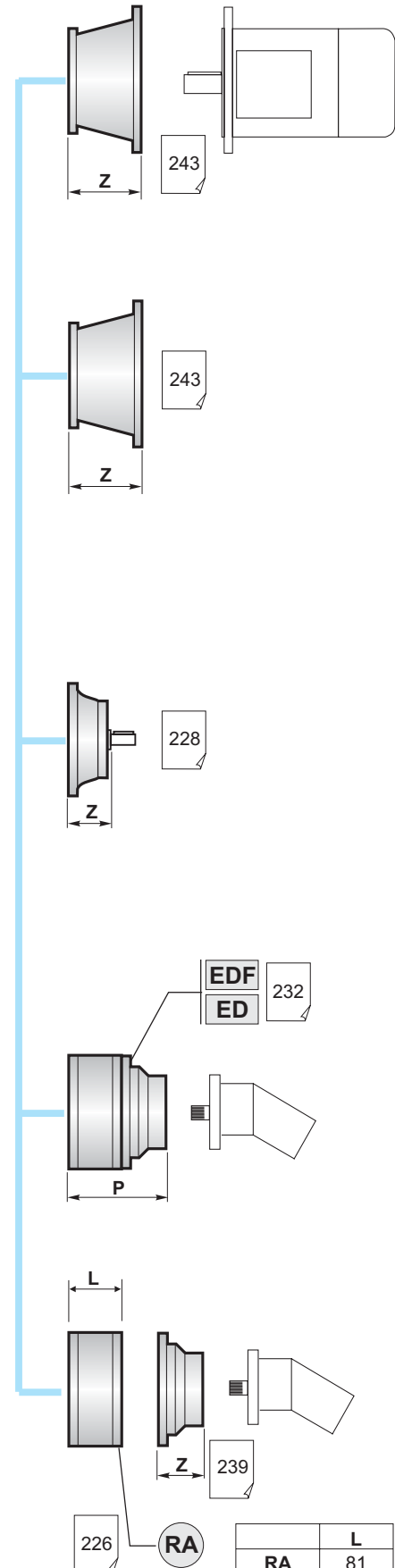

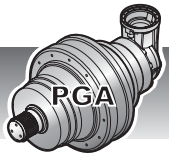

	PGA ...MS				
	A	B	RA	RB	EF
PGA 162	193	159	•	•	•
PGA 163	241	159	•	•	•
PGA 164	289	159	•	•	•

	PGA ...MC				
	A	B	RA	RB	EF
PGA 162	193	159	•	•	•
PGA 163	241	159	•	•	•
PGA 164	289	159	•	•	•

	PGA ...PS				
	A	B	RA	RB	EF
PGA 162	223	159	•	•	•
PGA 163	271	159	•	•	•
PGA 164	319	159	•	•	•

	PGA ...PC				
	A	B	RA	RB	EF
PGA 162	223	159	•	•	•
PGA 163	271	159	•	•	•
PGA 164	319	159	•	•	•

	PGA ...F				
	A	B	RA	RB	EF
PGA 162	193	159	•	•	•
PGA 163	241	159	•	•	•
PGA 164	289	159	•	•	•

	PGA ...FS				
	A	B	RA	RB	EF
PGA 162	193	159	•	•	•
PGA 163	241	159	•	•	•
PGA 164	289	159	•	•	•

	PGA ...CPC				
	A	B	RA	RB	EF
PGA 162	230	159	•	•	•
PGA 163	278	159	•	•	•
PGA 164	326	159	•	•	•

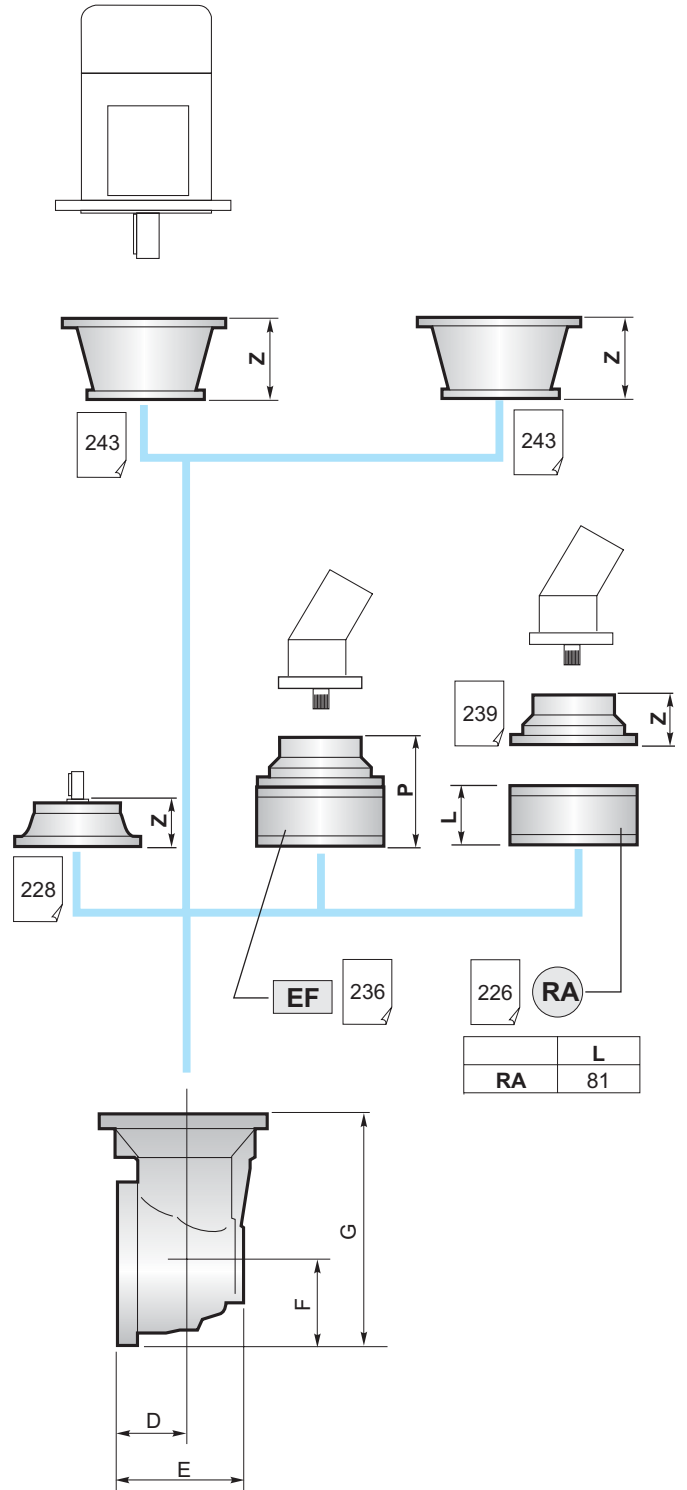

	D	E	F	G
PGA 162	75	141.5	93	252
PGA 163	75	141.5	93	252
PGA 164	75	141.5	93	252

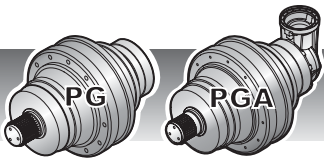

160

IT EN DE FR ES PT

YZ Pignoni / Pinion
Ritzel / Pignon
Piñones / Pinhões



	Versione Output type Abtriebs-version Version Versão	M	Z	XM	A	B	C	D	E	F	G	K	Materiale Material Matière Material Material	Code Code Bestell - Nr. Code Código Código
A	M.. - P..	1.9	20	0.049	65	—	6	20.5	84.5	42	42	—	38NiCrMo4	1701.200.042
	M.. - P..	5	16	2.5	55	—	6	20.5	95	42	42	—	38NiCrMo4	1701.259.042
B	M.. - P..	3.5	23	0	40	60.5	6	20.5	87.5	42	42	60	38NiCrMo4	1701.291.042

FF Fondello di arresto / Stop bottom plate
Endscheibe / Bouchon de fermeture
Tapón de detención / Fundo de batente

Code / Code
Bestell - Nr. / Code
Código / Código
5701.034.000

BS Boccola scanalata / Splined bushing
Innenverzahnte Buchse / Moyeu cannelé
Casquillo ranurado / Bucha estriada

Materiale / Material
Material / Matière
Material / Material
UNI C40
SAE 1040
DIN Ck40

Code / Code
Bestell - Nr. / Code
Código / Código
1710.100.076

KB Barra scanalata / Splined rod
Außenverzahnte Welle / Arbre cannelé
Barra ranurada / Barra estriada

Materiale / Material
Material / Matière
Material / Material
UNI 39NiCrMo3
bonificato / hardened and tempered
vergütet / bonifié
bonificado / endurecido e temperado

Code / Code
Bestell - Nr. / Code
Código / Código
1703.179.042

FL Flangia / Flange
Flansch / Bride
Brida / Flange

Code / Code
Bestell - Nr. / Code
Código / Código
1710.102.025

GA Giunto di attrito / Shrink disc
Schrumpfscheibe / Frette de serrage
Disco de contracción / Disco de contracción

Coppia max.
Max. torque
Max. Drehmoment
Couple max.
Momento máx.
Torque máx.
2.2 kNm

Code / Code
Bestell - Nr. / Code
Código / Código
9015.062.000

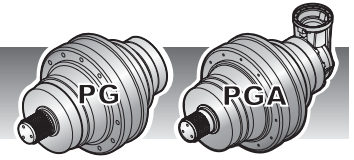

CARICHI RADIALI (Fr)

Nei diagrammi seguenti sono riportati i carichi radiali e i coefficienti K per rapportarli al valore $n_2 \times h$ desiderato.

RADIAL LOADS (Fr)

The following curves show the radial loads and the K factors to obtain the required $n_2 \times h$ value.

RADIALLAST (Fr)

In den nachstehenden Diagrammen ist die Radiallast und der Koeffizient K dargestellt und kann mit dem gewünschten Wert $n_2 \times h$ verglichen werden.

CHARGES RADIALES (Fr)

Dans les diagrammes suivants sont indiqués les charges radiales et les facteurs K de façon à obtenir la valeur $n_2 \times h$ désirée.

CARGAS AXIALES (Fr)

En los siguientes diagramas se indican las cargas radiales y los coeficientes K para obtener el valor requerido $n_2 \times h$.

CARGAS AXIAIS (Fr)

Nos diagramas seguintes são indicadas as cargas radiais e os coeficientes K para obter o valor $n_2 \times h$ desejado.

M - P - CPC*

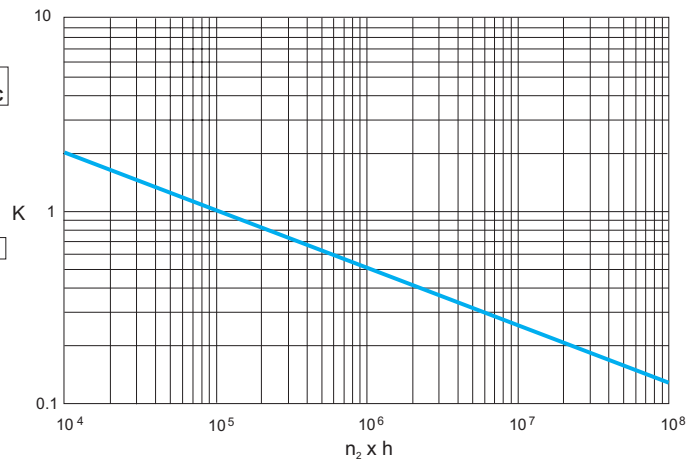
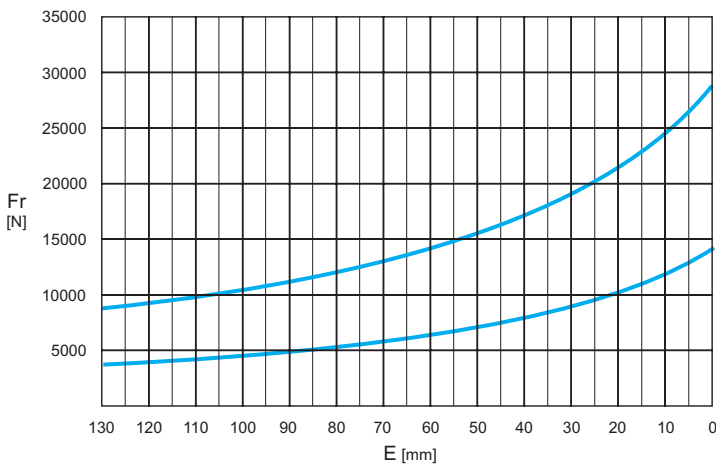

	$n \times h$				
	10^5	10^4	10^6	10^7	10^8
M - P	Fr		Fr • K		
*CPC	Fr • 0.75		Fr • K • 0.75		

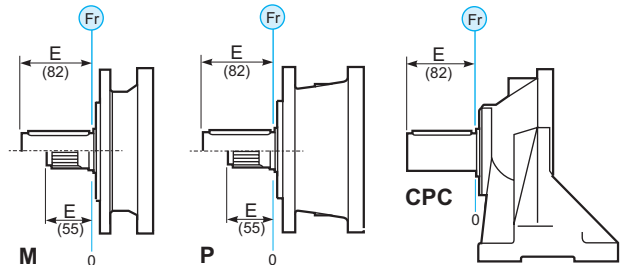

CARICHI ASSIALI (Fa)

I valori dei carichi assiali indicati in tabella sono riferiti alle versioni e alla direzione di applicazione del carico.

AXIAL LOADS (Fa)

The values of the axial loads in the table refer to the output versions and load direction of application.

AXIALLAST (Fa)

Die dargestellten Werte der Axiallast basieren auf der Version und der applizierten Lastrichtung.

CHARGES AXIALES (Fa)

Les valeurs des charges axiales indiquées dans le tableau se réfèrent aux versions et à la direction d'application de la charge.

CARGAS AXIALES (Fa)

Los valores de las cargas axiales indicados en la tabla se refieren a las versiones y a la dirección de aplicación de la carga.

CARGAS AXIAIS (Fa)

Os valores das cargas axiais indicadas na tabela referem-se às versões e à direção de aplicação da carga.

Fa [N]	M	P - CPC	← →
	16000	18000	

