

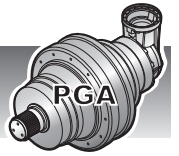

# 100

	i	Mc [kNm]				n1max [min <sup>-1</sup> ]	Pt [kW]	Kg				
		n <sub>2</sub> x h	n <sub>2</sub> x h	n <sub>2</sub> x h	n <sub>2</sub> x h			M	P	CPC	F	FS
		10.000	20.000	50.000	100.000							
<b>PG 101</b>	3.55	1.24	1.10	0.94	0.83	2800	12	13	15	18	11	14
	4.28	1.24	1.10	0.94	0.83							
	5.60	0.90	0.80	0.68	0.60							
	6.75	0.79	0.70	0.60	0.53							
	8.67	0.51	0.45	0.38	0.34							
<b>PG 102</b>	12.6	1.24	1.10	0.94	0.83	2800	8	19	21	24	17	20
	15.2	1.24	1.10	0.94	0.83							
	19.9	1.24	1.10	0.94	0.83							
	23.9	1.24	1.10	0.94	0.83							
	28.9	1.24	1.10	0.94	0.83							
	31.4	0.90	0.80	0.68	0.60							
	37.8	0.90	0.80	0.68	0.60							
	45.5	0.79	0.70	0.60	0.53							
	58.5	0.79	0.70	0.60	0.53							
	<b>PG 103</b>	54.1	1.24	1.10	0.94							
65.3		1.24	1.10	0.94	0.83							
70.7		1.24	1.10	0.94	0.83							
78.7		1.24	1.10	0.94	0.83							
85.3		1.24	1.10	0.94	0.83							
102.8		1.24	1.10	0.94	0.83							
111.5		1.24	1.10	0.94	0.83							
134.3		1.24	1.10	0.94	0.83							
161.9		1.24	1.10	0.94	0.83							
172.5		1.24	1.10	0.94	0.83							
207.9		1.24	1.10	0.94	0.83							
211.6		0.90	0.80	0.68	0.60							
255.1		0.90	0.80	0.68	0.60							
271.7		0.90	0.80	0.68	0.60							
307.5		0.79	0.70	0.60	0.53							
327.5		0.90	0.80	0.68	0.60							
394.8	0.79	0.70	0.60	0.53								
<b>PG 104</b>	337.3	1.24	1.10	0.94	0.83	2800	1.5	31	33	36	29	32
	365.7	1.24	1.10	0.94	0.83							
	396.4	1.24	1.10	0.94	0.83							
	440.8	1.24	1.10	0.94	0.83							
	477.8	1.24	1.10	0.94	0.83							
	531.3	1.24	1.10	0.94	0.83							
	575.9	1.24	1.10	0.94	0.83							
	624.4	1.24	1.10	0.94	0.83							
	694.2	1.24	1.10	0.94	0.83							
	752.6	1.24	1.10	0.94	0.83							
	836.8	1.24	1.10	0.94	0.83							
	907.1	1.24	1.10	0.94	0.83							
	966.3	1.24	1.10	0.94	0.83							
	1093.4	1.24	1.10	0.94	0.83							
	1144.5	1.24	1.10	0.94	0.83							
	1185.4	0.90	0.80	0.68	0.60							
	1318.0	1.24	1.10	0.94	0.83							
	1428.8	0.90	0.80	0.68	0.60							
	1692.3	1.24	1.10	0.94	0.83							
	3422.1	0.79	0.70	0.60	0.53							



	i	Mc [kNm]				n1max [min <sup>-1</sup> ]	Pt [kW]	Kg				
		n <sub>2</sub> x h	n <sub>2</sub> x h	n <sub>2</sub> x h	n <sub>2</sub> x h			M	P	CPC	F	FS
		10.000	20.000	50.000	100.000							
<b>PGA 102</b>	10.4	1.24	1.10	0.94	0.83	2800	8	28	30	33	26	29
	12.5	1.24	1.10	0.94	0.83							
	16.4	0.90	0.80	0.68	0.60							
	19.7	0.79	0.70	0.60	0.53							
<b>PGA 103</b>	37.0	1.24	1.10	0.94	0.83	2800	5	34	36	39	32	35
	44.6	1.24	1.10	0.94	0.83							
	53.8	1.24	1.10	0.94	0.83							
	58.4	1.24	1.10	0.94	0.83							
	70.3	1.24	1.10	0.94	0.83							
	84.8	1.24	1.10	0.94	0.83							
	91.9	0.90	0.80	0.68	0.60							
	110.8	0.90	0.80	0.68	0.60							
	133.6	0.79	0.70	0.60	0.53							
	171.5	0.79	0.70	0.60	0.53							
	<b>PGA 104</b>	131.8	1.24	1.10	0.94							
158.9		1.24	1.10	0.94	0.83							
191.5		1.24	1.10	0.94	0.83							
207.6		1.24	1.10	0.94	0.83							
230.8		1.24	1.10	0.94	0.83							
301.7		1.24	1.10	0.94	0.83							
327.0		1.24	1.10	0.94	0.83							
363.6		1.24	1.10	0.94	0.83							
394.2		1.24	1.10	0.94	0.83							
475.1		1.24	1.10	0.94	0.83							
515.3		0.90	0.80	0.68	0.60							
572.7		1.24	1.10	0.94	0.83							
610.1		1.24	1.10	0.94	0.83							
735.4		1.24	1.10	0.94	0.83							
797.2		0.90	0.80	0.68	0.60							
960.9		0.90	0.80	0.68	0.60							
1158.2		0.79	0.70	0.60	0.53							
1233.7		0.90	0.80	0.68	0.60							
1487.1		0.79	0.70	0.60	0.53							



(n<sub>2</sub> x h = 20.000)

$$M_{max} = M_c \times 2$$

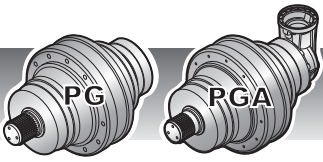

# 100

MS

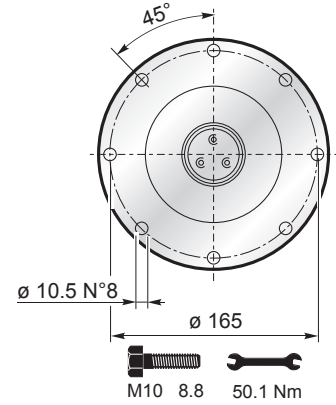
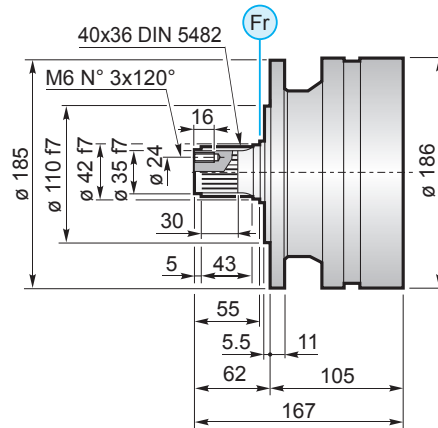
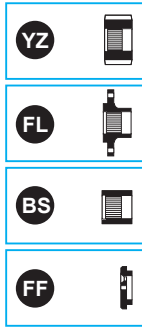

MC

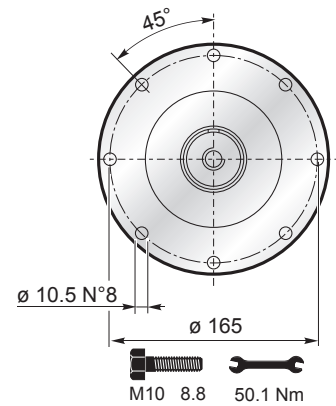
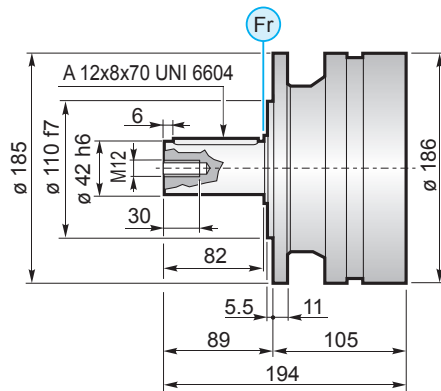

PS

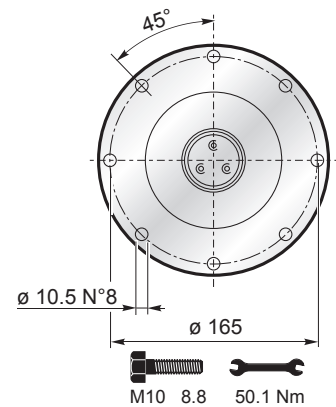
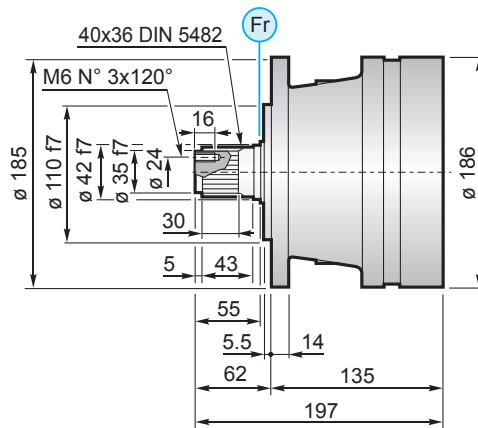
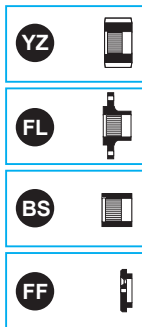

PC

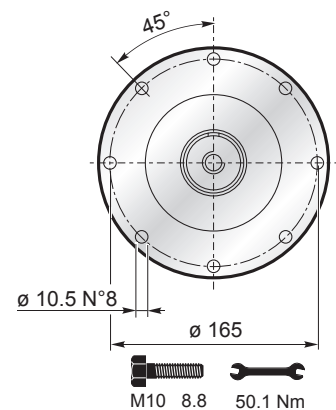
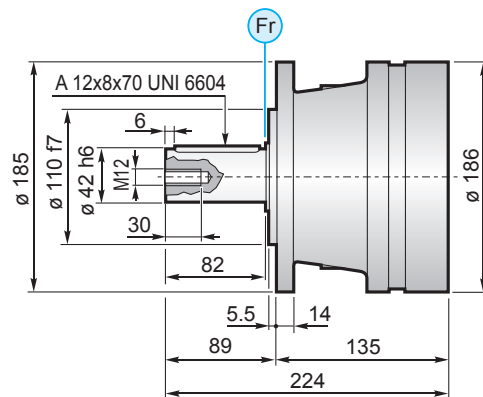

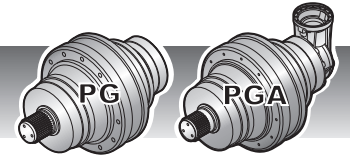

F

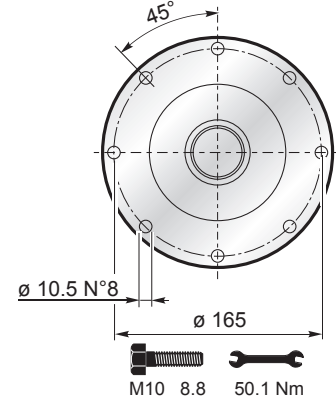
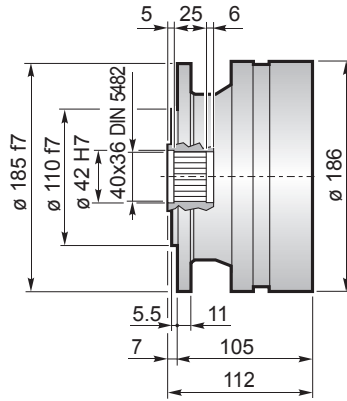
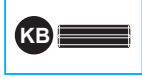

FS

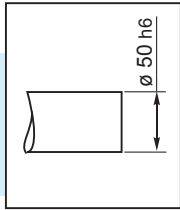
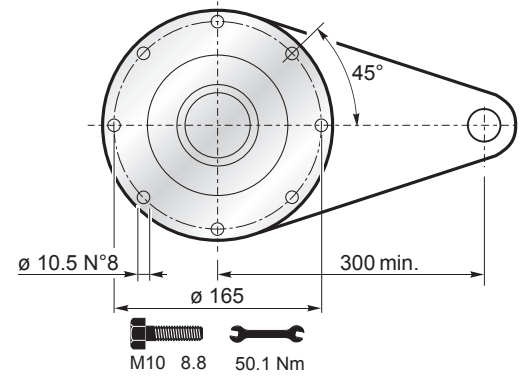
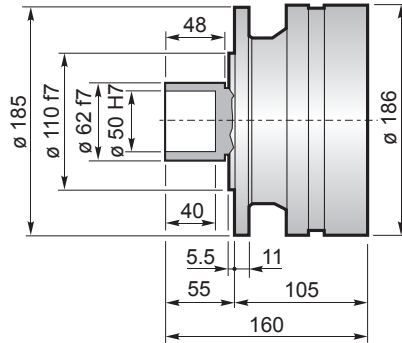

$M_{max} = 2.2 \text{ kNm}$

La coppia massima indicata è valida solo con calettatori forniti da Planetary Drives  
 The maximum torque indicated is valid only with shrink discs supplied by Planetary Drives  
 Das dargestellte, maximale Drehmoment gilt nur mit von Planetary Drives gelieferter Schrumpfscheibe  
 Le couple maximal indiqué n'est valable qu'avec les frettes de serrage fournis par Planetary Drives  
 El momento máximo indicado sólo es válido con discos de contracción suministrados por Planetary Drives  
 O torque máximo indicado é válido exclusivamente com discos de contração fornecidos pela Planetary Drives

CPC

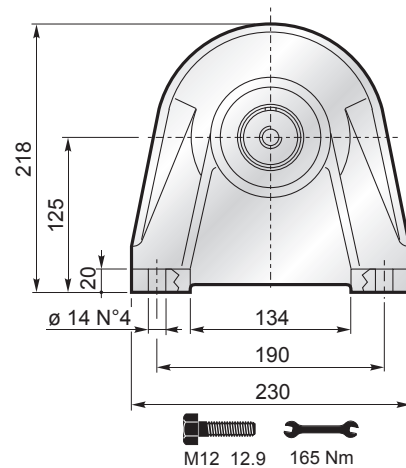
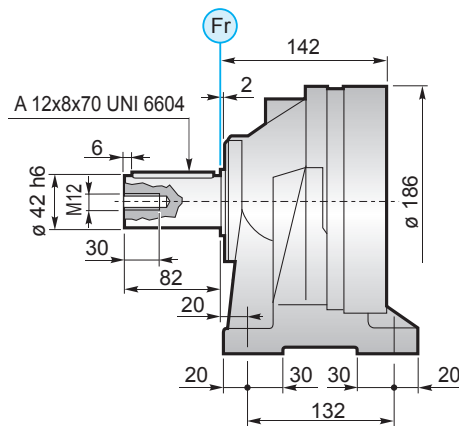

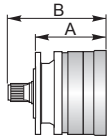

	PG ...MS					
	A	B	RA	RB	EF	EDF
PG 101	105	167	•			•
PG 102	153	215	•			•
PG 103	201	263	•			•
PG 104	249	311	•			•

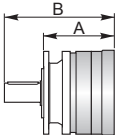
	PG ...MC					
	A	B	RA	RB	EF	EDF
PG 101	105	194	•			•
PG 102	153	242	•			•
PG 103	201	290	•			•
PG 104	249	338	•			•

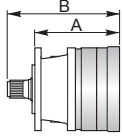
	PG ...PS					
	A	B	RA	RB	EF	EDF
PG 101	135	197	•			•
PG 102	183	245	•			•
PG 103	231	293	•			•
PG 104	271	341	•			•

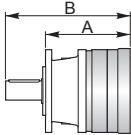
	PG ...PC					
	A	B	RA	RB	EF	EDF
PG 101	135	224	•			•
PG 102	183	272	•			•
PG 103	231	320	•			•
PG 104	279	368	•			•

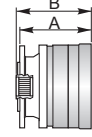
	PG ...F					
	A	B	RA	RB	EF	EDF
PG 101	105	112	•			•
PG 102	153	160	•			•
PG 103	201	208	•			•
PG 104	249	256	•			•

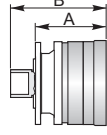
	PG ...FS					
	A	B	RA	RB	EF	EDF
PG 101	105	160	•			•
PG 102	153	208	•			•
PG 103	201	256	•			•
PG 104	249	304	•			•

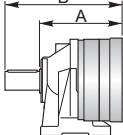
	PG ...CPC					
	A	B	RA	RB	EF	EDF
PG 101	142	224	•			•
PG 102	190	272	•			•
PG 103	238	320	•			•
PG 104	287	368	•			•

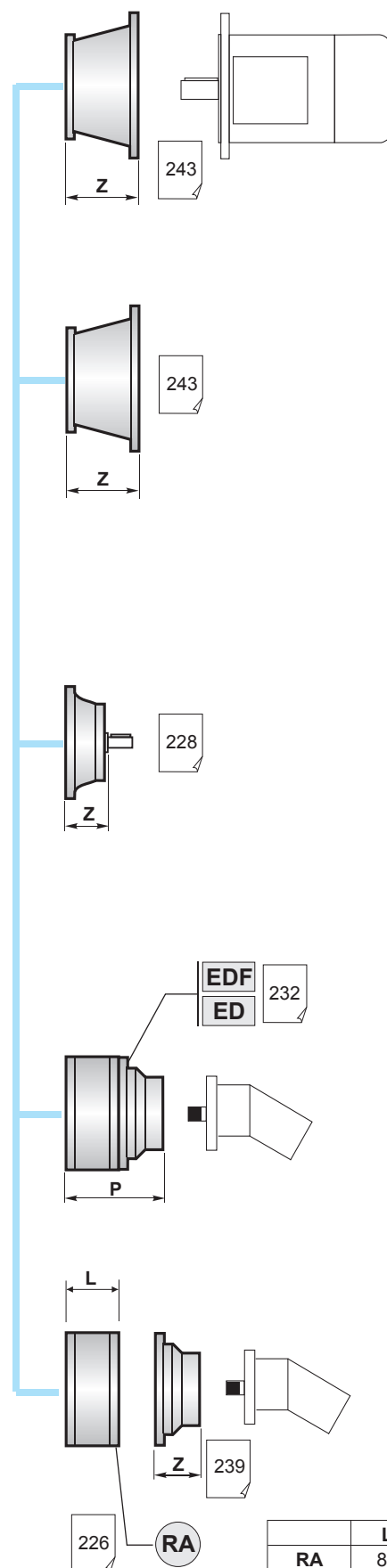

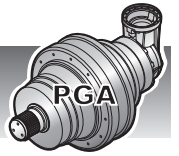

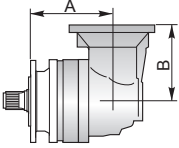
	PGA ...MS				
	A	B	RA	RB	EF
PGA 102	180	159	•		•
PGA 103	228	159	•		•
PGA 104	276	159	•		•

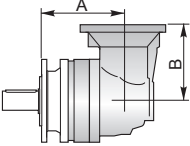
	PGA ...MC				
	A	B	RA	RB	EF
PGA 102	180	159	•		•
PGA 103	228	159	•		•
PGA 104	276	159	•		•

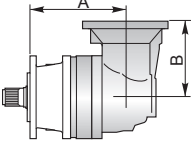
	PGA ...PS				
	A	B	RA	RB	EF
PGA 102	210	159	•		•
PGA 103	258	159	•		•
PGA 104	306	159	•		•

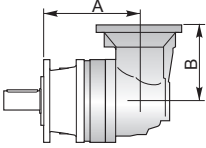
	PGA ...PC				
	A	B	RA	RB	EF
PGA 102	210	159	•		•
PGA 103	258	159	•		•
PGA 104	306	159	•		•

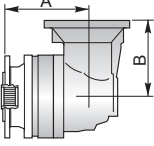
	PGA ...F				
	A	B	RA	RB	EF
PGA 102	180	159	•		•
PGA 103	228	159	•		•
PGA 104	276	159	•		•

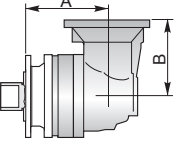
	PGA ...FS				
	A	B	RA	RB	EF
PGA 102	180	159	•		•
PGA 103	228	159	•		•
PGA 104	276	159	•		•

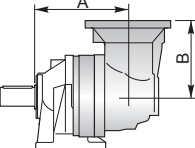
	PGA ...CPC				
	A	B	RA	RB	EF
PGA 102	217	159	•		•
PGA 103	265	159	•		•
PGA 104	313	159	•		•

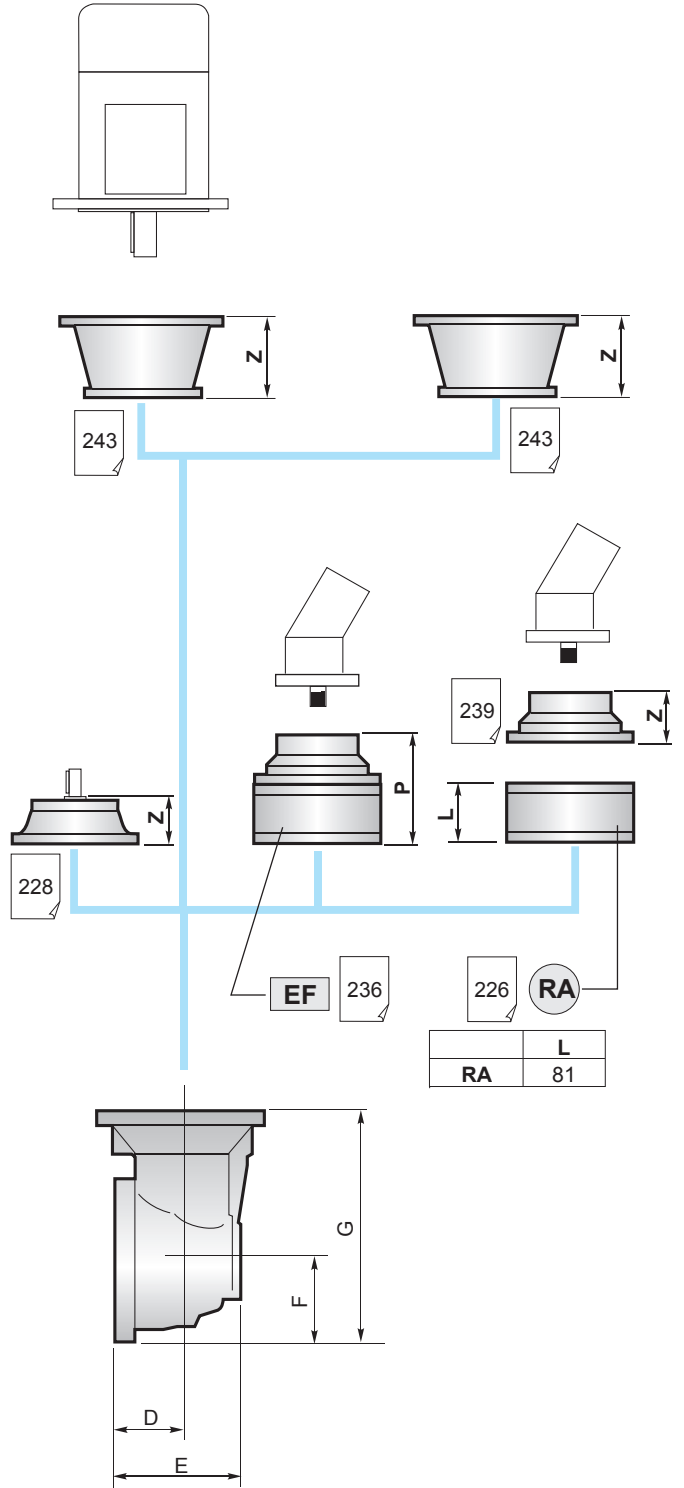

	D	E	F	G
PGA 102	75	141.5	93	252
PGA 103	75	141.5	93	252
PGA 104	75	141.5	93	252

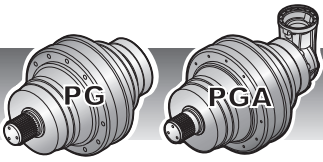

# 100

IT EN DE FR ES PT

**YZ** Pignoni / Pinion  
Ritzel / Pignon  
Piñones / Pinhões

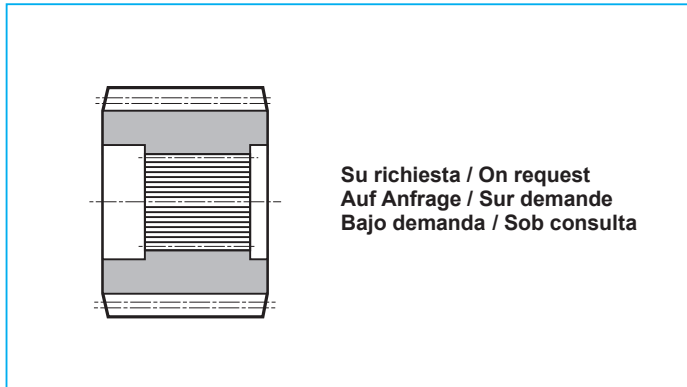

Su richiesta / On request  
Auf Anfrage / Sur demande  
Bajo demanda / Sob consulta

**FF** Fondello di arresto / Stop bottom plate  
Endscheibe / Bouchon de fermeture  
Tapón de detención / Fundo de batente

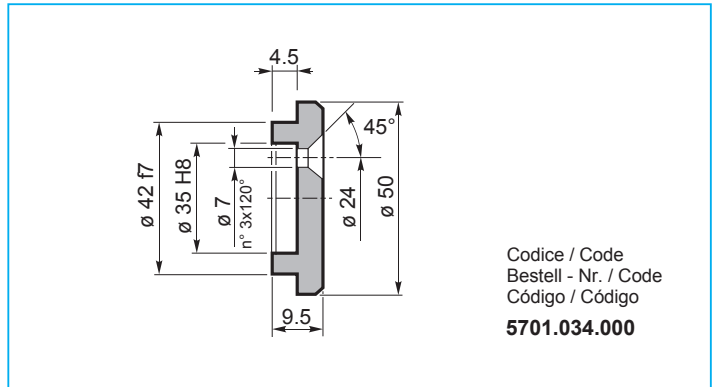

Codice / Code  
Bestell - Nr. / Code  
Código / Código  
**5701.034.000**

**BS** Boccola scanalata / Splined bushing  
Innenverzahnte Buchse / Moyeu cannelé  
Casquillo ranurado / Bucha estriada

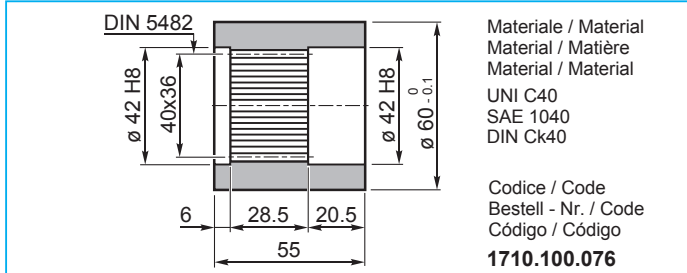

Materiale / Material  
Material / Matière  
Material / Material  
UNI C40  
SAE 1040  
DIN Ck40

Codice / Code  
Bestell - Nr. / Code  
Código / Código  
**1710.100.076**

**KB** Barra scanalata / Splined rod  
Außenverzahnte Welle / Arbre cannelé  
Barra ranurada / Barra estriada

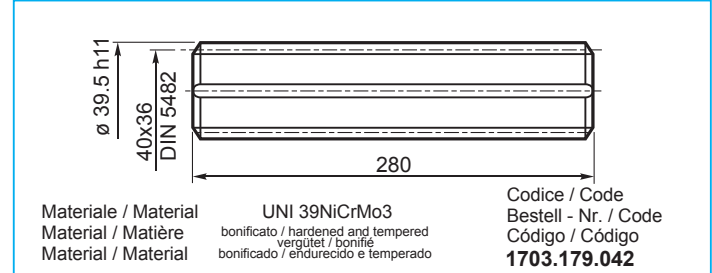

Materiale / Material  
Material / Matière  
Material / Material

UNI 39NiCrMo3  
bonificato / hardened and tempered  
vergütet / bonifié  
bonificado / endurecido e temperado

Codice / Code  
Bestell - Nr. / Code  
Código / Código  
**1703.179.042**

**FL** Flangia / Flange  
Flansch / Bride  
Brida / Flange

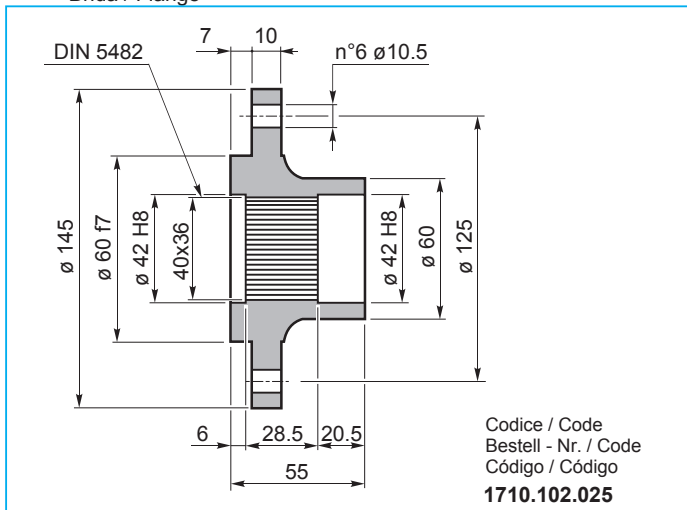

Codice / Code  
Bestell - Nr. / Code  
Código / Código  
**1710.102.025**

**GA** Giunto di attrito / Shrink disc  
Schrumpfscheibe / Frette de serrage  
Disco de contracción / Disco de contração

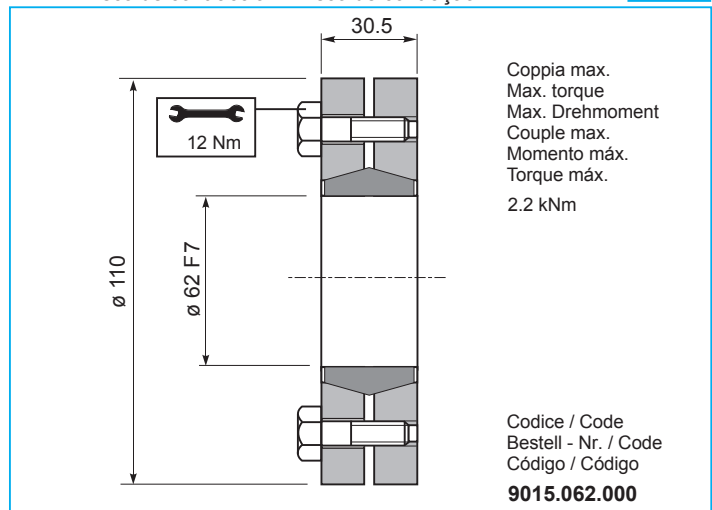

Coppia max.  
Max. torque  
Max. Drehmoment  
Couple max.  
Momento máx.  
Torque máx.  
2.2 kNm

Codice / Code  
Bestell - Nr. / Code  
Código / Código  
**9015.062.000**

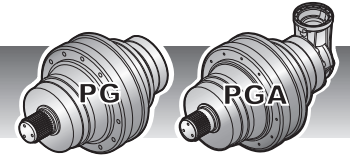

### CARICHI RADIALI (Fr)

Nei diagrammi seguenti sono riportati i carichi radiali e i coefficienti K per rapportarli al valore  $n_2 \times h$  desiderato.

### RADIAL LOADS (Fr)

The following curves show the radial loads and the K factors to obtain the required  $n_2 \times h$  value.

### RADIALLAST (Fr)

In den nachstehenden Diagrammen ist die Radiallast und der Koeffizient K dargestellt und kann mit dem gewünschten Wert  $n_2 \times h$  verglichen werden.

### CHARGES RADIALES (Fr)

Dans les diagrammes suivants sont indiqués les charges radiales et les facteurs K de façon à obtenir la valeur  $n_2 \times h$  désirée.

### CARGAS RADIALES (Fr)

En los siguientes diagramas se indican las cargas radiales y los coeficientes K para obtener el valor requerido  $n_2 \times h$ .

### CARGAS RADIAIS (Fr)

Nos diagramas seguintes são indicadas as cargas radiais e os coeficientes K para obter o valor  $n_2 \times h$  desejado.

## M - P - CPC\*

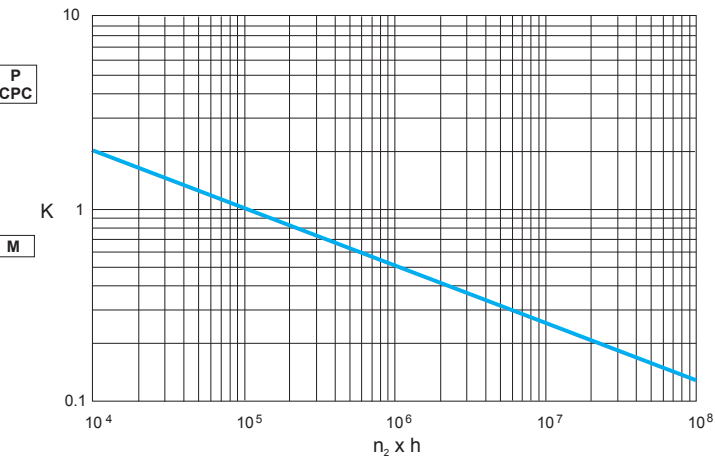
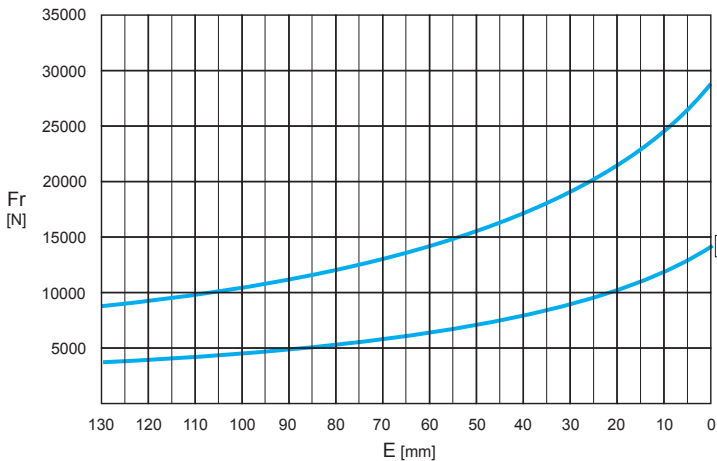

	$n \times h$			
	$10^5$	$10^4$	$10^6$	$10^7$
M - P	Fr		Fr • K	
*CPC	Fr • 0.75		Fr • K • 0.75	

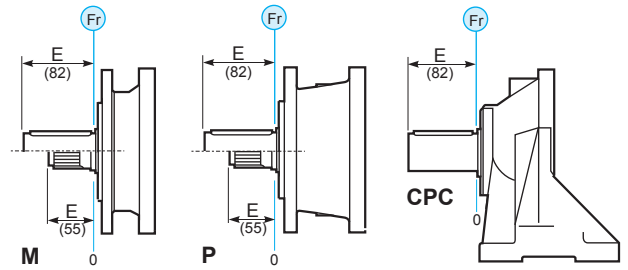

### CARICHI ASSIALI (Fa)

I valori dei carichi assiali indicati in tabella sono riferiti alle versioni e alla direzione di applicazione del carico.

### AXIAL LOADS (Fa)

The values of the axial loads in the table refer to the output versions and load direction of application.

### AXIALLAST (Fa)

Die dargestellten Werte der Axiallast basieren auf der Version und der applizierten Lastrichtung.

### CHARGES AXIALES (Fa)

Les valeurs des charges axiales indiquées dans le tableau se réfèrent aux versions et à la direction d'application de la charge.

### CARGAS AXIALES (Fa)

Los valores de las cargas axiales indicados en la tabla se refieren a las versiones y a la dirección de aplicación de la carga.

### CARGAS AXIAIS (Fa)

Os valores das cargas axiais indicadas na tabela referem-se às versões e à direção de aplicação da carga.

Fa [N]	M	P - CPC	
		16000	18000
	16000	18000	→

